

The Circuitry Underlying Rod Bipolar Cell Sensitization

by

Amanda M Travis

Department of Pharmacology and Cancer Biology
Duke University

Date: _____

Approved:

Vadim Y Arshavsky

Jeremy Kay

Cynthia Kuhn

David MacAlpine, Supervisor

Nina Sherwood

Dissertation submitted in partial fulfillment of
the requirements for the degree of Doctor
of Philosophy in the Department of
Pharmacology and Cancer Biology in the
Graduate School of Duke University

2017

ABSTRACT

The Circuitry Underlying Rod Bipolar Cell Sensitization

by

Amanda M Travis

Department of Pharmacology and Cancer Biology
Duke University

Date: _____

Approved:

Vadim Y Arshavsky

Jeremy Kay

Cynthia Kuhn

David MacAlpine, Supervisor

Nina Sherwood

An abstract of a dissertation submitted in partial
fulfillment of the requirements for the degree of
Doctor of Philosophy in the Department of
Pharmacology and Cancer Biology in the
Graduate School of Duke University

2017

Copyright by
Amanda Marie Travis
2017

Abstract

Dim light vision requires the dopamine D1 receptor for the sensitization of rod bipolar cells by GABA. However, the circuit behind this mechanism is poorly defined. We used electroretinogram recordings of mice with genetic and pharmacological manipulations to investigate the identity of the cells in the circuit controlling rod bipolar cell sensitivity. We found that tonic GABA input onto rod bipolar cells comes from a wide-field amacrine cell rather than horizontal cells. The output of this wide-field amacrine cell is directly regulated by voltage-gated sodium channels and dopamine-dampened serial inhibition, providing multiple regulatory sites for adaptation in the rod system.

Contents

Abstract	iv
List of Tables	viii
List of Figures	ix
1. Introduction	1
1.1 Cellular specialization in the retina	1
1.1.1 Photoreceptors	1
1.1.2 Cone System	3
1.1.3 Rod System	4
1.2 Rod Bipolar Cell Responses to Light	5
1.4 Retinal Interneurons	8
1.4.1 Horizontal Cells	8
1.4.2 Amacrine Cells	9
1.5 Measuring Retinal Function	11
1.6 Rod Bipolar Cell Resting Potential	13
1.7 Dopamine in the Retina	14
2. Materials and methods	17
2.1 Animals	17
2.2 Primary antibodies	18
2.3 Immunofluorescence analysis	19
2.4 Intravitreal injections	19

2.5 Electretinogram recordings	20
2.6 Electretinogram data analysis.....	21
3. Horizontal cells are not responsible for dopamine/GABA-dependent rod bipolar cell sensitization	24
3.1 Study background and objectives	24
3.2 Results	25
3.2.1 D1R expression can be specifically eliminated from horizontal cells	25
3.2.2 D1R expression in horizontal cells has no effect on RBC sensitivity	26
3.2.3 GABA release from horizontal cells has no effect on RBC sensitivity	28
3.3 Conclusion.....	28
4. GABA-dependent rod bipolar cell sensitization is driven by wide-field amacrine cells	30
4.1 Study background and objectives	30
4.2 Results	32
4.2.1 TTX-sensitive amacrine cell activity is required for normal RBC sensitivity ...	32
4.2.2 Blocking wide-field amacrine activity decreases RBC sensitivity by decreasing GABA release	33
4.2.3 TTX has no GABA _c R-independent effect on RBC sensitivity	35
4.3 Conclusions	36
5. Dopamine promotes sustained GABA release by modulating serial inhibition in wide-field amacrine cells	37
5.1 Study background and objectives	37
5.2 Results	38
5.2.1 Disrupting serial inhibition does not impact RBC sensitivity in response to full-field flashes	38

5.2.2 D1R inhibition does not decrease RBC sensitivity in the absence of serial inhibition.....	39
5.2.3 D1R activation increases b-wave amplitude independent of RBC sensitivity in the absence of serial inhibition	41
5.3 Conclusion.....	42
6. D1R expression in the retina.....	44
6.1 Study background and objectives	44
6.2 Results	45
6.2.1 D1R is expressed in a distinct subset of bipolar and amacrine cells	45
6.2.2 D1R is expressed in a subset of wide-field amacrine cells	47
6.3 Conclusion.....	48
7. Discussion	49
7.1 Regulation of RBC resting potential by light.....	49
7.2 Regulation of RBC sensitivity through lateral signaling	52
7.3 Regulation of RBC sensitivity by dopamine.....	53
7.4 Future studies of the RBC sensitivity circuit	54
7.5 Conclusions	55
References	56
Biography.....	63

List of Tables

Table 1: Measurements from electroretinogram recordings.....	22
--	----

List of Figures

Figure 1: The major cells of the rod and cone pathways.....	2
Figure 2: The major GABAergic interneurons of the rod system.....	9
Figure 3: Generation of D1R ^{β-gal/β-gal} and D1R ^{flox/flox} mouse lines.	17
Figure 4: D1R expression is eliminated in the horizontal cells of HC-D1R KO mice.....	25
Figure 5: WT and HC-D1R KO b-wave amplitudes and normalized rod bipolar cell sensitivity.	27
Figure 6: Normalized RBC sensitivity of HC-VGATKO mice in dim light.	28
Figure 7: Normalized RBC sensitivity after intravitreal TTX injection phenocopies GABA _A R KO mice.	31
Figure 8: B-wave implicit time is differentially affected by TTX and GABA _A R KO.....	32
Figure 9: RBC sensitivity after TTX injection is rescued by exogenous GABA.....	33
Figure 10: RBC sensitivity in GABA _A R KO mice is unaffected by TTX injection.....	34
Figure 11: RBC sensitivity after TTX injection in GABA _A R KO mice is not rescued by exogenous GABA.....	35
Figure 12: GABA has no GABA _A R-independent effect on RBC sensitivity.	36
Figure 13: Blocking GABA _A R has no effect on RBC sensitivity.....	39
Figure 14: Responses to flashes in dark-adapted retinas after blocking serial inhibition or D1R activity.....	40
Figure 15: Effect of dopamine on RBC sensitivity and b-wave amplitudes in the absence of serial inhibition.	42
Figure 16: Responses to flashes in dark-adapted, serial inhibition-free retinas with or without a D1R agonist.....	43
Figure 17: β -galactosidase expression in a tangential section of the D1R ^{β-gal/β-gal} retina. ...	45
Figure 18: D1R is not expressed by rod bipolar or starburst amacrine cells.	46

Figure 19: Retinal wholemount showing D1R+ wide-field amacrine cells.....47

Figure 20: Tangential retinal sections showing D1R+ wide-field amacrine cells. 48

Figure 21: Model for the circuitry underlying RBC sensitivity. 51

1. Introduction

The human visual system can function over a range of light of up to 10 orders of magnitude (Rodieck 1998). This remarkable capability begins in the retina, a thin layer of neural tissue at the back of the eye. Light is focused onto the retina and the photons are converted into a change in voltage in specialized light-sensitive neurons called photoreceptors. The tiling of these photosensitive neurons across the entire retina allows for the representation on the retina of every point in the visual field. The signal is then passed through the retina and projected to the visual cortex and other important areas of the brain that use visual input by a type of neuron called a retinal ganglion cell. This signal is never a straightforward representation of the exact quantity and quality of light at any given location. Instead, a lot of visual processing occurs in the retina before any signal reaches the brain. Critically, there is no single cell type with the processing power to differentiate small changes in light across the entire range of mammalian visual sensitivity. This limitation is overcome with both specialization and adaptation. Adaptation is critical for vision.

1.1 Cellular specialization in the retina

1.1.1 Photoreceptors

The first level of specialization in the retina is the existence of two types of photoreceptors. Every photoreceptor contains high concentrations of a photo-sensitive G-protein coupled receptor (GPCR) that undergoes a conformational change when the

bound chromophore is hit by a photon. This conformational change activates the heterotrimeric G-protein Transducin, and the alpha subunit of Transducin—now bound to GTP—activates a phosphodiesterase that cleaves cyclic GMP to GMP, closing a cGMP-gated cation channel that is open in the dark (Arshavsky & Burns 2014). This means that photoreceptors hyperpolarize, and therefore releases less glutamate, in response to light.

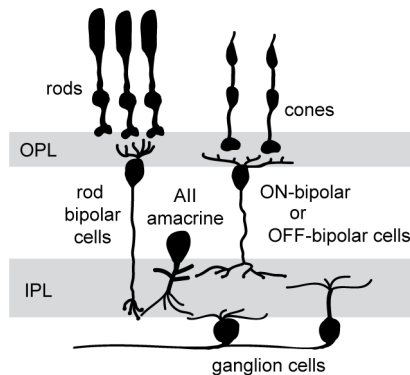

Figure 1: The major cells of the rod and cone pathways. Rod and cone photoreceptors synapse in the outer plexiform layer (OPL) onto specialized bipolar cells. In the inner plexiform layer (IPL), cone bipolar cells synapse directly onto the retinal output ganglion cells, but rod bipolar cells utilize the AII amacrine to signal to ganglion cells through cone bipolar cells. The cells illustrated here are glutamatergic except for the electrically-coupled, glycinergic AII.

The specialization at this level of vision comes from the existence of two types of photoreceptors, rods and cones, that express different types of photo-sensitive GPCRs. Rods contain rhodopsin, which is most sensitive to 498nm light, and cones, which are specialized for color vision, contain opsins that are sensitive to distinct wavelengths of light (Bowmaker & Dartnall 1980). In humans, there are cones that are activated by red,

green, or blue light. In mice, the only cone types are activated by green or blue light: S-cones have a protein called opsin that changes conformation when hit by a photon from 420nm light, and the opsin in M-cones responds best to 534nm light.

The precise responses of rods and cones to flashes of light, independent of wavelength, are also very different. Rods, specialized for dim light, have large and slow hyperpolarizing responses to light (Nikonov et al 2006). These responses are very sensitive but also easily saturated. When adapted to the dark, rods can detect single photons. However, these features keep rods from detecting bright light or quickly changing inputs. In fact, the rod system is completely saturated by normal outdoor lighting. Cone photoreceptors, on the other hand, have fast responses that provide superior spatial and temporal acuity.

In addition to having distinct responses to any possible input, these two types of photoreceptors also send their signals to two separate, parallel pathways with additional specialization (Figure 1). These parallel pathways allow the signals from rods and cones to be processed separately and further optimized for each required function.

1.1.2 Cone System

The direct pathway from cone signal to ganglion cell is very simple—there is a single cell, called a bipolar cell that receives input from cones and provides input to ganglion cells (Figure 1)—however, the cone system neurons are all very specialized for specific tasks. In the mouse, there are 14 types of bipolar cells in the cone system

(Shekhar et al 2016). The gross categories are the ON-type that depolarizes in the presence of light and the OFF-type that hyperpolarizes in the presence of light, but each type has a distinct morphology, connectivity, and protein expression profile. These bipolar cells connect to as many as 22 different ganglion cell types in the mouse (Volgyi et al 2009). This specialization results in many important types of information being collected and sent to the brain by the cone system (Masland 2012). Interneurons in the retina, specifically the horizontal cells and amacrine cells to be discussed later, provide the lateral feedback required for this processing. Among other functions, the light collected by cones provides both high acuity color vision (Kolb 1991) and motion detection (Yonehara et al 2011).

1.1.3 Rod System

The rod system sacrifices speed and acuity to allow for greater sensitivity and reliability. To this end, the rod system has only one type of photoreceptor (the rod) and one type of bipolar cell (the depolarizing rod bipolar cell or RBC). The convergence of around 30 rods onto a single RBC (Behrens et al 2016, Tsukamoto & Omi 2013) allows for RBCs to be much more sensitive than the rods themselves, while the divergence of around half of all rod to two different RBCs probably allows for some reduction in the noise and therefore an improvement in the signal-to-noise ratio (Demb & Singer 2012).

Rather than providing input onto their own specialized ganglion cells, the rod system uses the ganglion cells of the cone system via a specialized cell called the AII

amacrine cell. These cells receive glutamatergic input from RBCs and then provide input to cone ON-bipolar cells via electrical synapses. This allows the rod system to provide information under very dim light conditions without a dedicated class of ganglion cells for retinal output. AII amacrine cells are even more sensitive than the RBCs that provide input to them due, again, to convergence (10 to 20 RBCs provide input to each AII) but also strong gain at the RBC-AII synapse.

Although the rod system involves relatively few cell types and only one major function, there are many aspects of the rod system that remain poorly understood. One important aspect that requires further investigation is the adaptation of the rod system from a single photon detector to a system that can differentiate light 4 orders of magnitude brighter than that with no change in the cellular apparatus.

1.2 Rod Bipolar Cell Responses to Light

The three main sources of input to the RBC are glutamate, glycine, and GABA. In the dark, the glutamate that is released from rods due to the dark current binds to the metabotropic glutamate receptor mGluR6. mGluR6 binding results in heterotrimeric G-protein activation and the resulting G-protein cascade leads to the closure of the non-specific cation Trpm1 channel that is in the dendritic tips of RBCs near the mGluR6 (Koike et al 2010). This arrangement allows for a sign reversal at the RBC: glutamate leads to hyperpolarization rather than depolarization of the RBC so that light, which

causes hyperpolarization and less glutamate release from rod photoreceptors, causes depolarization and increased glutamate release from the rod bipolar cells. When a flash of light decreases the amount of glutamate released by a rod, the downstream rod bipolar cells become more depolarized.

RBCs do not have action potentials, the common neuronal mechanism that digitizes changes in membrane potential to all or nothing signaling events. Instead, they release glutamate based on graded potentials from a complex in their axon terminal called a ribbon synapse (Matthews & Fuchs 2010). Based on single cell electrophysiological recordings from RBCs, the resting potential in the dark is somewhere between -80 and -60 mV (Cangiano et al 2007). Flashes of light will open a fraction of Trpm1 channels proportional to the change in glutamate release from the synapses of the connected rod photoreceptors. Dim flashes will open a small fraction of Trpm1 channels, leading to a small depolarization and then a small increase in glutamate release from the RBC terminal. Bright flashes will result in very large increases in glutamate release from the RBC terminal. Of course, a short flash of light during complete darkness is not the typical paradigm under physiological conditions. The amount of illumination at any given time will translate to a relative level of depolarization and therefore glutamate release from bipolar cells. This means that any change in illumination at a single location is coded as a change from this previous baseline.

Although only photoreceptors provide glutamatergic input to RBCs, other types of neurons release neurotransmitters onto the RBCs that influence membrane potential and, therefore, RBC output. Most notably, RBCs express glycine receptors and two types of ionotropic GABA receptors, GABA_A and GABA_C (Euler & Masland 2000). These forms of feedforward or feedback shape the light responses of RBCs and therefore the signals that will eventually make it to the brain. When an RBC is held at the Trpm1 reversal potential (0 mV), there are distinct inputs from all three of these sources upon light onset. About 20% of the total charge transfer is through glycine channels, about 20% is through GABA_A channels, and about 60% is through GABA_C channels (Eggers & Lukasiewicz 2010). These inputs have distinct kinetics. Glycine receptors have responses that decay rapidly and GABA_A channels are self-inactivating. GABA_C channels are slower to open and remain open until the GABA dissociates from its binding site on the channel.

The opening of any of these anion channels under most conditions would allow the influx of chloride ions (Cl⁻) and a subsequent hyperpolarization of the RBC toward the reversal potential of Cl⁻ (~ -70 mV). In RBCs, that change in membrane voltage would have a very profound effect on the graded potential-based glutamate release. It would be expected that this feedback would lead to smaller responses from RBCs, and that is what is seen in single cell electrophysiology experiments in retinal slices (Eggers & Lukasiewicz 2006b, Shields & Lukasiewicz 2003). The combination of the

glutamatergic input from photoreceptors with the glycinergic and GABAergic input from retinal interneurons determines the output of a rod bipolar cell.

1.4 Retinal Interneurons

1.4.1 Horizontal Cells

Horizontal cells are responsible for lateral signaling in the outer plexiform layer (OPL). In the mouse, horizontal cells have complex dendritic and axonal processes connected by a long, thin axon. The dendrites surround the cone to cone bipolar cell synapses, and the axonal processes surround the rod to rod bipolar cell processes (Kolb 1974). Both locations express ionotropic glutamate receptors, so horizontal cells are depolarized in the dark due to photoreceptor glutamate release and become hyperpolarized in response to light. The neurotransmitter of horizontal cells is GABA, although there has been controversy about horizontal cell GABA release and the ultimate answer may change from species to species. Mouse horizontal cells do release GABA (Deniz et al 2011).

The horizontal cell soma and associated dendritic processes are important for providing information to the cone to cone bipolar synapse about the light level over a large area of the retina. This allows for the development of a center-surround response in cone bipolar cells (Nelson & Kolb 1983). Because horizontal cell axon terminals also receive both rod and cone input (direct rod input and cone input via the axon) (Trumpler et al 2008), it would make sense that the horizontal axonal terminal processes

serve an analogous purpose in the rod system: transmission of global illumination condition to each rod to RBC synapse. However, a function for the horizontal cell axon terminal in the rod system has never been demonstrated.

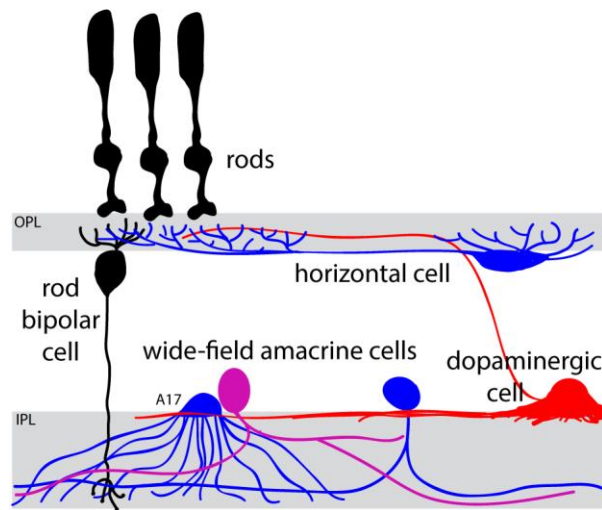

Figure 2: The major GABAergic interneurons of the rod system. The cells that release GABA onto rod bipolar cells are blue, the dopaminergic cell is red, and the wide-field amacrine that provides serial inhibition to other wide-field amacrines is in purple.

1.4.2 Amacrine Cells

Amacrine cells have cell bodies either in the inner nuclear or ganglion cell layer and processes in the very wide but very vertically organized inter plexiform layer (IPL). There are at least 25 different sub-types of amacrine cell (MacNeil et al 1999) and they can be broken down into classes using a combination of morphology and neurotransmitter.

Narrow-field amacrine cells release glycine as their primary neurotransmitter and are responsible for vertical integration. The previously mentioned AII amacrine cell

(Figure 1) is one well-characterized example. The AII receives glutamatergic input from RBCs at the very bottom of the IPL and then provides an electric signal to cone ON bipolar cells but also releases glycine onto OFF bipolar cells in the upper part of the IPL. There are over 10 other types of narrow-field amacrine cells with their own specific functions in the cone system.

Although around 15% of amacrine cells release neither glycine or GABA (Kay et al 2011), most of the amacrine cells that do not release glycine release GABA. A few of these cells are well-defined. For example, the starburst amacrine cell has a clearly established role in setting up the direction-selectivity of cone-driven direction-selective ganglion cells through the release of both GABA and the neurotransmitter acetylcholine. However, most GABAergic neurons, especially the 16 wide-field amacrine cells as defined by morphology (Lin & Masland 2006), have unknown functions.

It is likely, due to the large number of cone bipolar cells and cone processing channels, that most amacrine cell types are important for cone system rather than rod system function. However, in addition to the AII amacrine, there is another amacrine cell type that exclusively serves the rod system: the A17 amacrine cell. RBCs release glutamate directly onto both AII and A17 amacrine cells. The A17 cell (Figure 2) forms a reciprocal synapse that releases GABA back onto the RBC terminal in response to that glutamatergic input. Each individual synapse of the A17 releases GABA due to a local increase in calcium entering through Ca²⁺-permeable AMPA-type glutamate receptors

(Chavez et al 2006) rather than due to depolarization of the entire A17 cell. This GABA release, at the sites of the RBC with GABA_A receptors (Chavez et al 2010), shapes the RBC response at each individual terminal in a way that reduces signal to noise for the rod to AII synapse (Grimes et al 2015).

There is extensive GABAergic input to both the direct cone and direct rod pathways. There is also extensive GABAergic signaling among the amacrine cells themselves. While GABA_c receptors are heavily concentrated on bipolar cells, GABA_A receptors are found both on bipolar cells and amacrine cells. In single-cell electrophysiological recordings from retinal slices, blocking GABA_A receptors increased overall GABA_cR input to RBCs (Eggers & Lukasiewicz 2006a), indicating that serial inhibitory circuits exist upstream of bipolar GABA_cR activation (purple cell in Figure 2 releases GABA onto other amacrine cells rather than rod bipolar cells).

1.5 Measuring Retinal Function

Although single cell recordings from rod system neurons provide a lot of valuable information about channel composition, response kinetics, and synaptic relationships, these types of recordings disrupt physiological ion concentrations and any synaptic inputs that are influenced by long range circuits. To preserve the retina as an unperturbed tissue, a type of recording called an electroretinogram (ERG) is utilized. An ERG is performed by placing an electrode on the cornea and recording the difference in

electric field potential between that electrode and a reference electrode while the eye is subjected to changes in illumination (Robson & Frishman 1998).

Due to the vertical organization of the retina, the signal arising from different cell populations is at least partially separated temporally. Hyperpolarizations and depolarizations occur in a stereotyped order with a stereotyped relative amplitude. Photoreceptors hyperpolarize first, but in dark-adapted conditions, the convergence of rod photoreceptors to rod bipolar cells means that the subsequent depolarization of RBCs swamps any small rod hyperpolarization for dim flashes. At higher flash intensities, the trace begins with a downward deflection that occurs due to the rod hyperpolarization governed by the photoreceptor G-protein cascade (Breton et al 1994). This downward deflection is called an a-wave. The upward deflection that follows is called a b-wave. The b-wave is caused by depolarization of RBCs (Robson et al 2004). The size of the b-wave then is a measurement of the total response in RBCs with brighter flashes of light causing larger b-waves. The other major feature of the ERG waveform is a set of fast wavelets laying over the rising phase of the b-wave called oscillatory potentials. These are thought to be caused by neurons in the inner retina (Wachtmeister 1998).

ERGs have long been used to diagnose retinal diseases that result in photoreceptor degeneration (Birch & Fish 1987). If there are fewer photoreceptors collecting photons, the a-wave and then subsequent b-wave will be proportionally

smaller. However, ERG recordings can provide much more information than just a straight forward read-out of photoreceptor health and function. The prominent nature of the b-wave allows for an examination of how the b-wave changes in response different stimulus paradigms (Hetling & Pepperberg 1999), the elimination of certain proteins from the retina (McCall & Gregg 2008), or the pharmacological manipulation of cell or receptor activity (Dong & Hare 2003, Robson et al 2004). A previous study in this lab found that genetic elimination of either GABA_AR or the dopamine D1 receptor results in a decrease in the response of rod bipolar cells as measured by b-wave amplitude in both the dark-adapted retina and in the presence of dim background illumination (Herrmann et al 2011).

1.6 Rod Bipolar Cell Resting Potential

Maintenance of resting potential is very important for neuronal function. Like other neurons, potassium ions are a major driving force for the establishment of a hyperpolarized resting potential (Tessier-Lavigne et al 1988). The sodium-potassium pump builds up a potassium ion concentration gradient, with more potassium on the inside of the cell. Because potassium leak channels allow much greater permeability to potassium than other ions, potassium ions to flow out of the cell with its concentration gradient. A membrane potential gradient is generated as the positive potassium ions build up on the outside of the cell until the competing forces of concentration and ionic

potential have reached an equilibrium. This equilibrium, though much more complicated than described here, sets the resting potential of the rod bipolar cell.

In the rod bipolar cell, potassium ions are also very important for extrusion of chloride ions via the K^+/Cl^- co-transporter KCC2 (Vu et al 2000). A large chloride ion gradient is important for the previously mentioned $GABA_A$ inputs, but this large chloride gradient is generated at the expense of the potassium gradient. The electrical solution is to substitute part of the outward potassium leak with an inward chloride input: tonic $GABA_A$ activation (Herrmann et al 2011).

This mechanism explains the seemingly paradoxical effect on rod bipolar cell responses in the absence of $GABA_A$. Although GABA input to rod bipolar cells via $GABA_A$ causes smaller responses to light in single cell electrophysiological recordings (Eggers & Lukasiewicz 2006a), the $GABA_A$ knock-out mouse has smaller rather than larger responses during ERG recordings (Herrmann et al 2011). Tonic GABA input to rod bipolar cells hyperpolarizes the RBC resting membrane potential.

1.7 Dopamine in the Retina

Dopamine is a modulatory neurotransmitter with many documented effects on the retina. It is released by a specific retinal interneuron (Figure 2), and various dopamine receptors are expressed in the retina. The general pattern of dopamine release, more dopamine when lights are brighter (Iuvone et al 1978) and more dopamine during the circadian day (Doyle et al 2002), has long led to a common association

between dopamine and the retinal process of light adaptation, and there are many studies that examine the role of dopamine in the cone system. For example, dopamine receptor D4 is important for circadian rhythm regulation (Jackson et al 2012), and dopamine receptor D2 is an important auto-receptor for regulatory feedback onto the retinal dopaminergic neurons (Veruki 1997, Wang et al 1997) .

The dopamine D1 receptor (D1R) is the receptor most important for the following studies. D1R is highly expressed by horizontal cells and not expressed by photoreceptors (Herrmann et al 2011). The cellular localization of D1R expression in the inner retina is more difficult to ascertain. The synaptic nature of D1R localization results in a dense milieu of D1R staining throughout the IPL. There is slightly more D1R expression in the layers of the IPL that correspond to ON-pathway synapses (layers closer to the ganglion cell layer), but no indication of the precise cell types with D1R expression when using immunostaining with a D1R antibody. A recent paper looked closely at retinal bipolar cell D1R expression using a mouse with BAC-transgenic expression of a fluorescent marker at the D1R locus. It was found to be expressed by a specific subset of bipolar cells, 3 types of OFF bipolar cells and 4 types of ON bipolar cells (Farshi et al 2016) but, importantly, not rod bipolar cells.

The most widespread role of D1R in the retina appears to be the regulation of gap junctions. Almost every retinal cell type has extensive homotypic gap junctions that allow for horizontal signaling across the retina. In many cell types, most notably

horizontal cells and AII amacrine cells, activation of the dopamine receptor D1 has been shown to close these gap junctions, inhibiting cell-cell coupling (Hampson et al 1992, Kothmann et al 2009, McMahon et al 1989, Mills et al 2007, Weiler et al 2000). In practice, this means that cell-cell coupling throughout the retina is most extensive in dim light and blocked in bright light. It is speculated that this action helps drive the retinal machinery away from the needs of the slow rod system, increasing sensitivity through optimization of the signal-to-noise ratio, and toward the needs of the parallel cone system framework, high acuity and quick responses. The role of D1R activation in this switch is again evidence for the importance of D1R as a proxy for the level of background illumination.

The only established role for D1R in the rod system is in the regulation of GABA-driven rod bipolar cell sensitivity (Herrmann et al 2011). Because D1R is not expressed in RBCs and the lowered sensitivity of RBCs in the $D1R^{-/-}$ mouse can be rescued by the addition of exogenous GABA, there is a D1R-sensitive cell in the retina that regulates GABA release onto rod bipolar cells.

2. Materials and methods

2.1 Animals

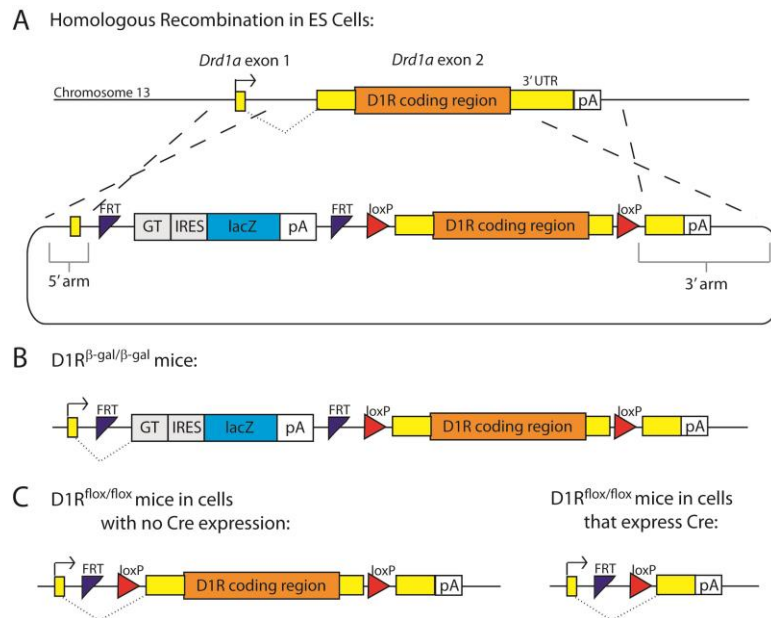

Figure 3: Generation of D1R^{β-gal/β-gal} and D1R^{fllox/fllox} mouse lines. The cassette illustrated here underwent homologous recombination (A) to generate mice with *lacZ* transcription (B) or floxed *Drd1a* (C) at the D1R allele. Arrows indicate transcription start sites, the poly A transcription termination site is labeled pA, the slice acceptor site that drives transcription of the new cassette is labeled GT, and IRES is the internal ribosome entry site that allows for translation of the *lacZ* gene.

C57Bl/6 (WT) mice were purchased from Jackson Labs (Bar Harbor, ME).

GABACR^{-/-} mice were described in (McCall et al 2002) and have been backcrossed onto a C57Bl/6 background. The D1R^{β-gal/β-gal} mouse strain (Figure 3B) was generated by the trans-NIH Knock-Out Mouse Project (KOMP) via homologous recombination at the D1R allele in ES cells (Figure 3A), obtained from the KOMP Repository (www.komp.org),

and then backcrossed with C57Bl/6 mice for 9 generations. To obtain D1R^{flox/flox} mice, the D1R^{β-gal/β-gal} line was bred with Gt(ROSA)^{26Sortm2(FLP*)Sor} (Jackson Labs) to obtain offspring with complete FRT site recombination (Figure 3C). The resulting line with backcrossed with C57Bl/6 for 9 generations. Cx57^{Cre} mice were described in (Hirano et al 2016) and VGAT^{flox/flox} were a gift to Jackson Labs from Dr. Bradford B. Lowell, Beth Israel Deaconess Medical Center, Harvard Medical School. Animals were reared under a normal day/night cycle and handled per the protocol approved by the Institutional Animal Care and Use Committees of Duke University. All experiments were performed during the day.

2.2 Primary antibodies

The primary antibodies used in these studies were: rat anti-D1R (1:500, Sigma, D187), rabbit anti-calbindin (1:1000, Millipore, AB1778), rabbit anti-β-galactosidase (1:5000, a gift from Jeremy Kay, Duke University), mouse anti-PKCα H-7 (1:1000, Santa Cruz, sc-8393 Lot#I1306), goat anti-Bhlhb5 E-17 (1:500, Santa Cruz, sc-6045 Lot#K1414), and goat anti-Choline Acetyltransferase (1:400, Millipore, AB144P). Secondary goat anti-rat or anti-mouse and donkey anti-goat, anti-rabbit, or anti-mouse antibodies were Alexa Fluor 488, Alexa Fluor 594, or Alexa Fluor 647 (1:500, Invitrogen). Nuclei were stained using DAPI (Sigma-Aldrich).

2.3 Immunofluorescence analysis

Mouse eyes were enucleated and the posterior eyecups were dissected and then fixed for 1 hour in 4% paraformaldehyde, rinsed in PBS, cryoprotected in 30% sucrose, and embedded in OCT embedding medium (Tissue-Tek, Sakura). Retinal cross sections of 16µm were collected using a cryostat microtome (Microm HM 550). Sections were rehydrated with PBS, treated with a solution to block nonspecific binding (5% goat or donkey serum in PBS with 0.2% Triton X-100) for 1 hour, incubated in primary antibodies in the same blocking solution for 3 hours, washed three times, incubated in secondary antibodies in blocking solution, and then finally washed three more times. The same general procedure but without cryoprotection and OCT embedment were used to process retinal whole mounts. The retinas were dissected away from the retinal pigment epithelium before fixation and the incubation times for primary and secondary antibodies were 3 days and 1 day, respectively.

Both retinal sections and whole mounts were then mounted with Fluoromount G (Electron Microscopy Sciences, Hatfield, PA) under glass coverslips. Images were acquired using a Nikon Eclipse 90i confocal microscope and a C1 confocal scanner controlled by EZ-C1 v 3.10 software (Nikon).

2.4 Intravitreal injections

Intravitreal injections were performed using a syringe with a 33 gauge, 12 degree beveled needle (Hamilton, Reno, NV) under dim red light. The following compounds

from Tocris (Bristol, UK) or Sigma were dissolved in PBS and then a volume of 1uL was injected: GABA (200mM, Sigma), tetrodotoxin (TTX, 10uM, Tocris), SR-95531 (2-(3-Carboxypropyl)-3-amino-6-(4 methoxyphenyl)pyridazinium bromide, 200 uM, Sigma), SKF 83566 (8-Bromo-2,3,4,5-tetrahydro-3-methyl-5-phenyl-1H-3-benzazepin-7-ol hydrobromide, 200uM, Tocris), and SKF 81297 ((±)-6-Chloro-2,3,4,5-tetrahydro-1-phenyl-1H-3-benzazepine hydrobromide, 500uM, Tocris). Recordings began 20 minutes after injection.

2.5 Electroretinogram recordings

Electroretinograms (ERGs) were recorded from 8-12 week old, dark-adapted mice as described in (Herrmann et al., 2011) using the Espion E2 system with a ColorDome ganzfeld stimulator (Diagnosys LLC, Littleton, MA). 6-12 weeks old mice were anesthetized by an intraperitoneal injection of 100 mg/kg ketamine and 10 mg/kg xylazine. Pupils were dilated with a mixture of 1% cyclopentolate-HCl and 2.5% phenylephrine. Eyes were kept lubricated during the recordings by a 1% carboxymethylcellulose sodium gel (Allergan, Parsippany, NJ). Body temperature was maintained by a heated platform. Simultaneously recording were made from both eyes using gold contact lens electrodes (), with stainless steel needle electrodes (Ocuscience, Henderson, NV) in the mouth for reference and at the base of the tail to ground. ERG signals were sampled at 1 kHz and recorded with 0.15 Hz low frequency and 500 Hz high frequency cut-offs. Responses to flashes from 0.0003 cd s/m² to 100 cd s/m² with

averaged trials of 10 to 1 and inter-flash intervals of 5 sec to 180 sec were recorded in the dark and then recorded at increasing background intensities (0.001, 0.01, 0.1 cd/m²) after two minutes of adaptation. In our experimental setup, the 456 nm background light activated rhodopsin at the rate of ~540 isomerization per rod every second (R*/rod/s).

2.6 Electroretinogram data analysis

The data from the electroretinogram recordings were analyzed using MATLAB 2016a (The MathWorks, Inc, Natick, MA). Oscillatory potentials were removed from the signals by 55 Hz FFT low-pass frequency filtering. The amplitude of the b-wave was calculated from baseline to the peak for dimmer flashes and from the bottom of the a-wave to the b-wave peak for brighter flashes. The other pieces of data extracted from the traces are defined in Table 1. The amplitude and rise time of the a-wave (AWAVEA and AWAVERT) are important controls that every condition is influencing rod bipolar cell responses directly rather than the responses of the photoreceptors that are providing the rod bipolar cells with what should glutamatergic input that is based only the interplay between background illumination and flash intensity. Maximum AWAVEA is a measure of total active photoreceptor volume, and AWAVERT is a function of the rate constant of photoreceptor phosphodiesterase activation downstream of rhodopsin activation

(Breton et al 1994).

Table 1: Measurements from electroretinogram recordings

PROPERTY	DEFINITION
AWAVEA	a-wave amplitude measured from baseline to the bottom of the a-wave (μV)
AWAVEIT	a-wave implicit time, time after the flash that the a-wave peaks (ms)
AWAVERT	time between the a-wave reaching 20% and 80% of the maximum value (ms)
BWAVEO	time after the flash that the b-wave begins (ms)
BWAVEA	b-wave amplitude measured from baseline to the bottom of the a-wave (μV)
BWAVEIT	b-wave implicit time, time after the flash that the b-wave peaks (ms)
kBWAVEA	maximum rate of rise for the b-wave ($\mu\text{V}/\text{ms}$)
kBWAVEIT	time after the flash that kBWAVEA occurs (ms)

Rod bipolar cell sensitivity was determined at each background illumination for every eye. After plotting b-wave amplitudes as a function of flash intensity, the stimulus-response curves were fit with Matlab using the following equation:

$$R = R_{max,1} \frac{I^{n_1}}{I^{n_1} + I_{0.5,1}^{n_1}} + R_{max,2} \frac{I^{n_2}}{I^{n_2} + I_{0.5,2}^{n_2}} \quad (\text{Equation 1})$$

$R_{max,1}$ is the maximal response amplitude, n_1 is the Hill coefficient, and $I_{0.5,1}$ is the half-saturating flash intensity for the rod-mediated responses. The second term of *Equation 1* characterizes the cone-mediated response. Sensitivity (S) for the rod system was then determined by dividing the maximal response amplitude by the half-saturating flash intensity for the set of flashes at each background light level:

$$S = \frac{R_{max,1}}{I_{0.5,1}} \quad (\text{Equation 2})$$

After normalizing to the S of the control dataset (usually WT mice) in the dark-adapted retina, the relationship between S and background light for each genotype or pharmacological manipulation can then be fit using the Weber-Fechner equation:

$$S/S_{dark,WT} = \frac{1}{1 + \left(\frac{I_b}{I_{half}}\right)^n} \quad (\text{Equation 3})$$

I_b is the background light intensity, I_{half} is the background luminance that causes a half-maximal reduction of S , and n is the Hill coefficient. In the following text, S will be referred to as rod bipolar cell or RBC sensitivity.

3. Horizontal cells are not responsible for dopamine/GABA-dependent rod bipolar cell sensitization

Rod bipolar cell sensitivity is important for visual function in dim light, and both D1R expression in a group of non-RBC retinal neurons and GABA release directly onto the RBCs are required for normal rod bipolar cell sensitivity. However, the identity of the cells expressing D1R or the cells responsible for this GABA release are unknown. In this chapter, we demonstrate that the source of the dopamine-dependent GABA release is not horizontal cells.

3.1 Study background and objectives

One possible source of GABAergic feedback onto rod bipolar cells are the horizontal cells. Horizontal cell processes are in the outer plexiform layer where rods synapse with rod bipolar cells, and electrophysiology of RBCs has shown there can be activation of GABA_A receptors at the dendritic tips on the RBCs (Herrmann et al 2011), a location with only horizontal cells as a source of GABA.

Horizontal cells are a major location of D1R expression in the retina. Interestingly, when D1R is absent in the D1R^{-/-} mouse, horizontal cells abnormally retain GABA (Herrmann et al 2011), suggesting that absent D1R could result in less GABA release. This relationship between D1R and GABA release would fit the data regarding the effects of both D1R and GABA_AR on rod bipolar cell sensitivity. If the D1R on horizontal cells is important for this rod bipolar cell sensitization mechanism,

eliminating D1R or eliminating GABA release from horizontal cells should phenocopy the RBC sensitivity seen in the $D1R^{-/-}$ and $GABA_{AcR}^{-/-}$ mice.

In this study, we aimed to determine 1) whether D1R expression on horizontal cells is required for rod bipolar sensitivity and 2) whether GABA release from horizontal cells is required for rod bipolar sensitivity.

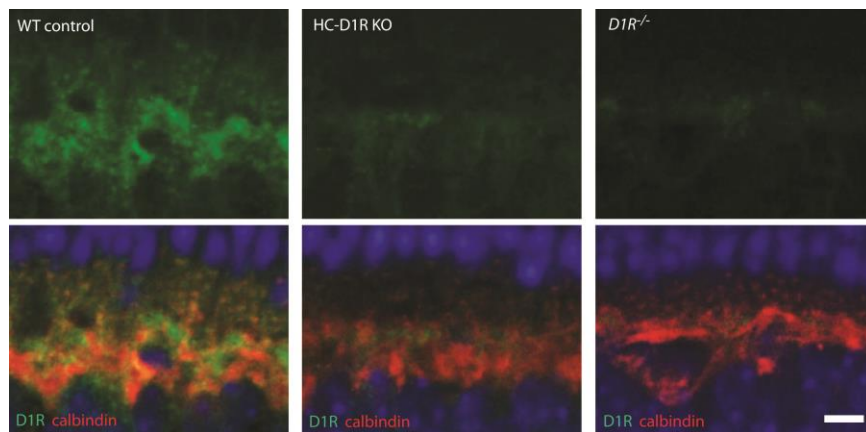

Figure 4: D1R expression is eliminated in the horizontal cells of HC-D1R KO mice. D1R (green) and horizontal cell marker calbindin (red) colocalize in WT mice but D1R is not in horizontal cells in the HC-D1R KO and $D1R^{-/-}$ mice (bar - 5 μ m)

3.2 Results

3.2.1 D1R expression can be specifically eliminated from horizontal cells

We generated a conditional knockout mouse that does not express D1R specifically in horizontal cells. LoxP sites were inserted around Exon 2 of the *Drd1a* gene (see methods in Chapter 2.1, Figure 3). This exon contains the entire coding region for the D1R protein. When bred with mice expressing Cre recombinase in place of one allele

of the horizontal cell-specific protein, connexin 57 (Hirano et al 2016), the resulting Cx57- $Cre^{+/-}D1R^{flox/flox}$ (HC-D1RKO) mice showed a nearly complete elimination of D1R immunostaining in horizontal cells (Figure 4). The remaining staining is likely a combination of non-specific antibody binding, as seen in the $D1R^{-/-}$ control, and D1R expression in cone bipolar cells.

3.2.2 D1R expression in horizontal cells has no effect on RBC sensitivity

HC-D1R KO mice and their WT littermates (Cx57- $Cre^{+/-}D1R^{wt/wt}$) were subjected to a series of flashes of increases intensity in the dark and then in the presence of increasing background illumination and ERGs were recorded. The average b-wave amplitudes from these measurements in the control group are plotted in Figure 5A. As background illumination increases, a flash of the same intensity has a smaller b-wave. The rod-dominated part of the curve, which reaches about 400 μV in amplitude with no background light, also decreases in sensitivity (*Equation 2*)—with a decrease in maximum amplitude and an increase in the flash intensity that elicits half-maximal response—when background light is applied. Figure 5B shows the results from the recordings of HC-D1R KO mouse responses. There is no appreciable difference in responses between mice with or without D1R expression in horizontal cells. This is further highlighted by graphing the responses of the two groups in the dark together with the responses from HC-D1R KO mice post-D1R antagonist SCH-23390 intravitreal injection (Figure 5C). The D1 antagonist is working through non-horizontal cell

receptors to decrease RBC responses, and this is also true in the presence of background light. At all levels of background illumination, HC-D1R KO mice phenocopy the rod bipolar cell sensitivity of WT mice rather than mice with no D1R activity (Figure 5D).

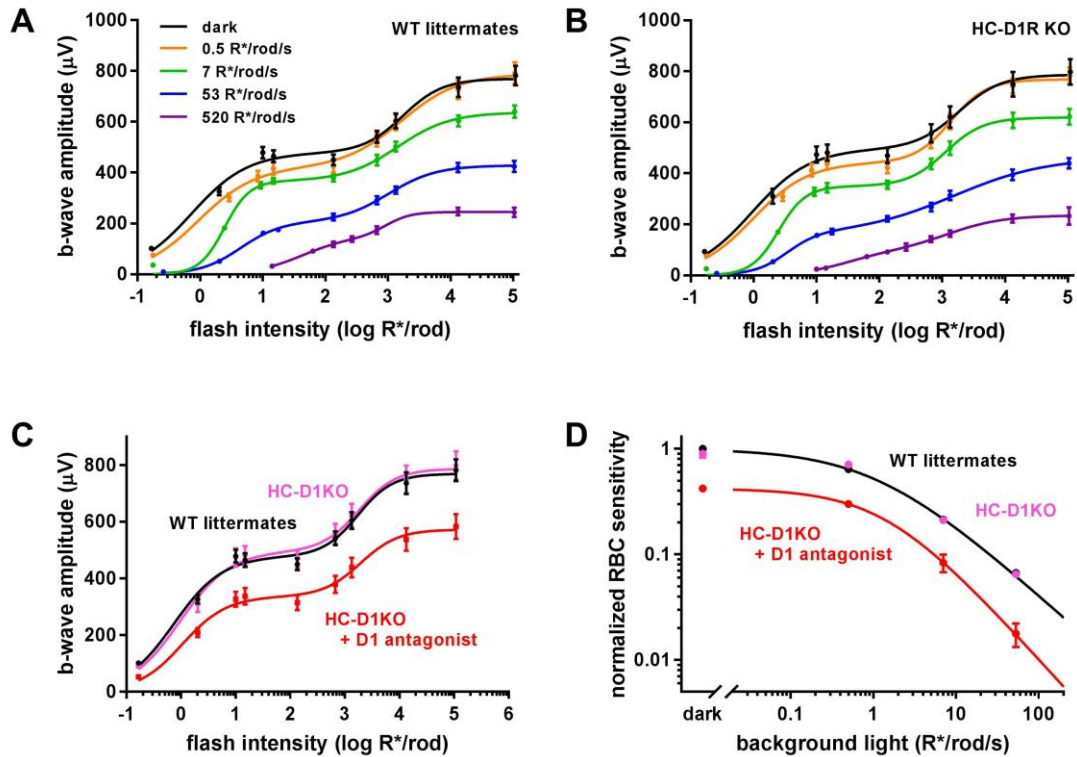

Figure 5: WT and HC-D1R KO b-wave amplitudes and normalized rod bipolar cell sensitivity. The b-wave amplitudes of WT (A) and HC-D1R KO (B) mice were graphed by flash intensity at 5 different levels of background illumination. The data from the dark-adapted condition of both groups was combined with data from HC-D1R KO mice injected with the D1R antagonist SCH 23390 (C) and then the normalized RBC sensitivity at each background light level for each experimental group is shown in (D). The data is fit using either *Equation 1* from methods (A, B, C) or a Weber-Fechner equation (*Equation 3*; D).

3.2.3 GABA release from horizontal cells has no effect on RBC sensitivity

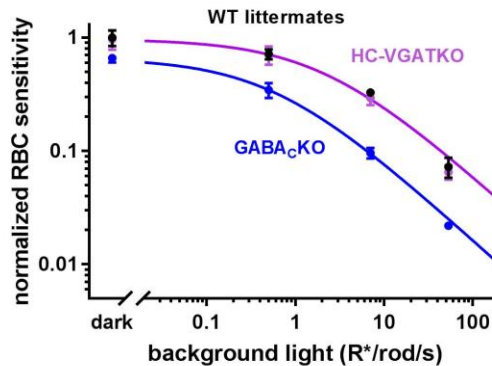

Figure 6: Normalized RBC sensitivity of HC-VGATKO mice in dim light. RBC sensitivity normalized by the RBC sensitivity for WT mice in the dark and then graphed by background illumination and fit using a Weber-Fechner equation for WT (black), HC-VGAT KO (purple), and GABA_cKO (blue) mice.

HC-VGAT KO mice (Cx57-Cre^{+/-} VGAT^{flox/flox}) and their WT littermates were subjected to the same series of flashes of increases intensity in the dark and then in the presence of increasing background illumination. There was no difference in RBC sensitivity under any condition (Figure 6). The RBC sensitivities in the GABA_cR KO mouse were significantly lower, as previously published (Herrmann et al 2011).

3.3 Conclusion

In this study, we showed that horizontal cells are not the source of rod bipolar cell sensitizing GABA release. The cell upstream of the rod bipolar cell in this mechanism must release GABA in a D1-dependent manner. Neither D1 expression nor GABA release from horizontal cells has any effect on RBC responses. The data rule out

horizontal cells as a part of the dopamine/GABA-dependent RBC sensitizing circuit. This conclusion is also consistent with recent data that D1R activity decreases calcium channel currents in isolated horizontal cells (Liu et al 2016), a property that would lead to increased rather than decreased GABA release in the absence of D1R activation. Clearly, more work is needed to understand the relationship between D1R activation and GABA release from horizontal cells, as well as the functional role of GABA_AR located in the rod bipolar cell dendrites.

4. GABA-dependent rod bipolar cell sensitization is driven by wide-field amacrine cells

GABA-dependent rod bipolar cell sensitization, as determined in the last chapter, is driven by GABA release in the inner plexiform layer. However, there are many GABAergic amacrine cells in the retina. In this chapter, we demonstrate that a wide-field amacrine cell is the voltage-gated sodium (Nav) channel-dependent source of the GABA release.

4.1 Study background and objectives

There are two types of wide-field amacrine cells that synapse on RBC axons based on experiments in retinal slices. A17 amacrine cells form a reciprocal synapse and drive Nav-independent GABA_AR activation (Chavez et al 2010, Chavez et al 2006). There are also non-reciprocal GABA inputs. Although these GABA-releasing cells have not been well-defined, it is known that they release GABA onto GABAC receptors at the RBC axon terminal and that the GABA is released due to action potentials (Chavez et al 2010).

In addition to the information known due to single cell electrophysiological recordings, there is data from ERG experiments that indicate that the non-A17 amacrine cells are the more likely candidate for participation in this RBC sensitization mechanism. Inactivation of A17 amacrine cells using the neurotoxin DHT, a serotonin analog,

increases b-wave amplitude (Dong & Hare 2003) and does not decrease RBC sensitivity (Smith et al 2015).

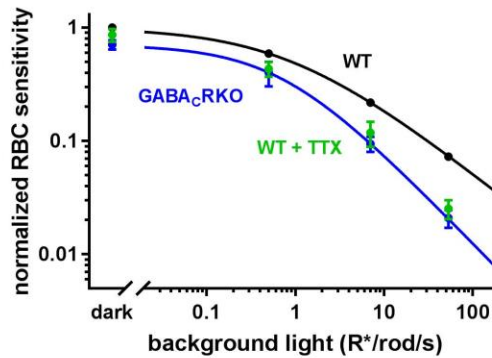

Figure 7: Normalized RBC sensitivity after intravitreal TTX injection phenocopies GABA_cR KO mice. RBC sensitivity normalized by the RBC sensitivity for WT mice in the dark and then graphed by background illumination and fit using a Weber-Fechner equation for WT (black), WT after intravitreal injection of TTX (green), and GABA_cKO (blue) mice.

There is also ERG evidence supporting non-A17 amacrine cells as the GABA source from ERG experiments. The drug tetrodotoxin (TTX), which blocks Nav-dependent action potentials, can be used to block GABA release from these wide-field cells. After intravitreal injection of TTX, b-wave amplitudes (Smith et al 2013) and RBC sensitivities (Smith et al 2015) are reduced. However, with the importance of Nav channels to neuronal function, TTX is a drug that has numerous effects in the retina.

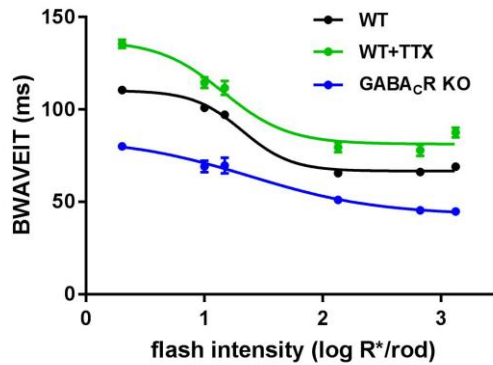

Figure 8: B-wave implicit time is differentially affected by TTX and GABA_cR KO. The time after the flash that b-wave maximum occurs for each flash intensity in WT (black), WT after intravitreal injection of TTX (green), and GABA_cR KO (blue) mice.

In this study, we aimed to determine whether a TTX-sensitive wide-field amacrine cell is responsible for the GABA_cR-dependent, RBC sensitizing GABA release.

4.2 Results

4.2.1 TTX-sensitive amacrine cell activity is required for normal RBC sensitivity

WT (C57Bl/6) mice underwent ERG recordings after intravitreal injection of TTX. Shown with the results for control WT mice and GABA_cR^{-/-} mice, TTX injection phenocopies the effects of GABA_cR elimination on RBC sensitivity (Figure 7).

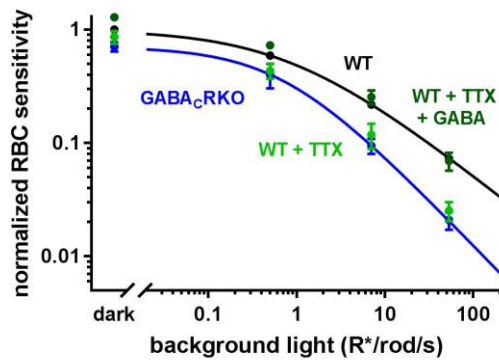

Figure 9: RBC sensitivity after TTX injection is rescued by exogenous GABA. RBC sensitivity normalized by the RBC sensitivity for WT mice in the dark and then graphed by background illumination and fit using a Weber-Fechner equation for WT (black), WT after intravitreal injection of TTX (green), co-injection of TTX and GABA (forest green), and GABA_cKO (blue) mice.

4.2.2 Blocking wide-field amacrine activity decreases RBC sensitivity by decreasing GABA release

TTX changes many aspects of the ERG waveform. For example, TTX causes a significant delay in the b-wave (BWAVEIT) for every flash intensity in the dark-adapted retina. This change is due to effects of TTX independent of GABA_c, because the GABA_cR^{-/-} mouse instead has a much faster implicit time than the WT mouse (Figure 8).

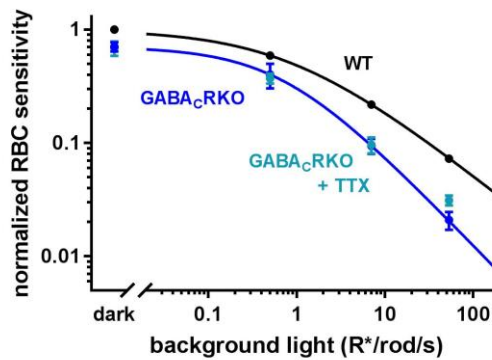

Figure 10: RBC sensitivity in GABA_cR KO mice is unaffected by TTX injection. RBC sensitivity normalized by the RBC sensitivity for WT mice in the dark and then graphed by background illumination and fit using a Weber-Fechner equation for WT (black), GABA_cKO after intravitreal injection of TTX (teal), and GABA_cKO (blue) mice.

Therefore, it is very important to determine that the decrease in sensitivity that results from TTX is due to a decrease in GABA input to the rod bipolar cell and not some other mechanism. If TTX is blocking GABA release onto the RBC, then injecting exogenous GABA should rescue the RBC sensitivity phenotype. Indeed, when GABA is co-injected with TTX, there is no longer any decrease in RBC sensitivity (Figure 9).

4.2.3 TTX has no GABA_cR-independent effect on RBC sensitivity

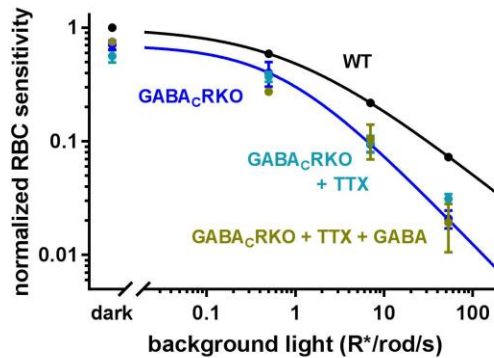

Figure 11: RBC sensitivity after TTX injection in GABA_cKO mice is not rescued by exogenous GABA. RBC sensitivity normalized by the RBC sensitivity for WT mice in the dark and then graphed by background illumination and fit using a Weber-Fechner equation for WT (black), GABA_cKO after intravitreal injection of TTX (teal), co-injection of TTX and GABA in GABA_cKO (gold), and GABA_cKO (blue) mice.

Although GABA rescued the effects of TTX on RBC sensitivity, there is still a possibility that a non-GABA_cR-dependent circuit is being activated. To test this possibility, GABA_cR^{-/-} mice were injected intravitreally with TTX and subjected to the same battery of tests (Figure 11). There was no change in the RBC sensitivity when compared to GABA_cR^{-/-} without TTX injection, indicating a lack of non-GABA_cR effect on RBC sensitivity by TTX. Additionally, co-injecting TTX and GABA into GABA_cR^{-/-} mice or injecting only GABA again phenocopied the GABA_cR^{-/-} mouse (Figure 12), indicating that GABA also has no GABA_cR-independent role in determining RBC sensitivity. If GABA_cR is not present, GABA_AR function—even though it involves a

GABA-gated chloride channel consisting of almost all the subunits as GABA_ACR—is not able to replace it.

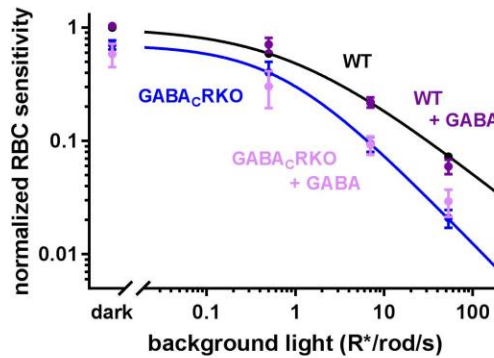

Figure 12: GABA has no GABA_ACR-independent effect on RBC sensitivity. RBC sensitivity normalized by the RBC sensitivity for WT mice in the dark and then graphed by background illumination and fit using a Weber-Fechner equation for WT (black), GABA_cCRKO after intravitreal injection of GABA (pink), GABA injection in WT (purple), and GABA_cCRKO (blue) mice.

4.3 Conclusions

In this chapter, we showed that rod bipolar cell sensitizing GABA is released by TTX-sensitive wide-field amacrine cells. TTX has no off-target effects on this aspect of the ERG waveform. The data confirm that it is an uncharacterized wide-field, and not the action potential-free A17 amacrine cell, that is important for RBC sensitization.

5. Dopamine promotes sustained GABA release by modulating serial inhibition in wide-field amacrine cells

Although previous chapters confirmed the identity of the cell that releases GABA directly onto rod bipolar cells in this sensitization mechanism as a wide-field amacrine, the role of D1R in the mechanism still has not been determined. In this chapter, we demonstrate that D1R suppresses GABAergic inhibition of the wide-field amacrine cell responsible for GABA_C-driven RBC sensitization.

5.1 Study background and objectives

The location of D1R in the circuit underlying rod bipolar cell sensitivity is unknown. From the above data, it is possible that the circuit is very simple—containing only a light-responsive, TTX-sensitive wide-field amacrine cell that requires D1R activation to release GABA onto the GABA_C receptors of rod bipolar cells. However, it is also possible that D1R is working upstream of the primary wide-field amacrine cell in a more complex circuit.

Because D1R acting at one of these proposed locations would have to have the opposing effect at the other location to explain the data, one place to start in investigating this question is with the usual role of D1 in neuronal excitability. In the striatum, there is evidence of D1R activation leading to cellular depolarization (Arias-Montano et al 2007, Podda et al 2010), but data from the retina indicates that D1R activation can inhibit Nav channel function to decrease neurotransmitter release (Hayashida et al 2009, Ichinose & Lukasiewicz 2007, Ogata et al 2012).

If the circuit is more complicated, it is likely to involve serial inhibition of the primary GABA-releasing wide-field amacrine cell. Because GABA_cR expression in the mouse is restricted to bipolar cells but serial inhibition is mediated by GABA_A receptors, inhibiting GABA_AR can isolate the primary wide-field from the rest of the potential circuit.

In this study, we aimed to determine whether D1R is located (1) on the wide-field amacrine cell responsible for direct RBC-sensitizing GABA_cR activation or (2) on an upstream interneuron that influences rod bipolar cell sensitivity through modulation of serial inhibition of the amacrine cell responsible for direct RBC-sensitizing GABA_cR activation.

5.2 Results

5.2.1 Disrupting serial inhibition does not impact RBC sensitivity in response to full-field flashes

The GABA_AR inhibitor gabazine (SR-93351) can block serial inhibition in the retina (Eggers & Lukasiewicz 2010). Because GABA_AR are also located on rod bipolar cells, it is important to understand the effects of gabazine on the rod-driven ERG. Gabazine leaves only the first oscillatory potential intact (Figure 14A), an interesting result considering that blocking inhibition might be expected to increase neuronal activity overall. Importantly, as shown in previous studies (Herrmann et al 2011), blocking GABA_AR had no effect on RBC sensitivity at any level of background

illumination (Figure 13). This would seem to indicate that D1R is functioning downstream of any serial inhibition.

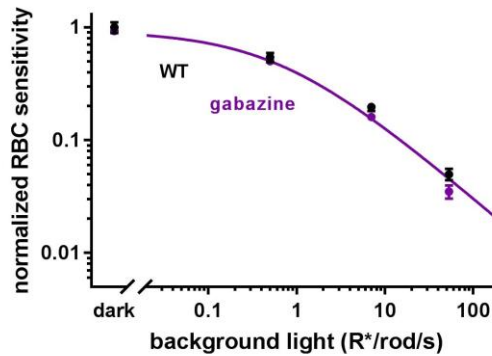

Figure 13: Blocking $GABA_A$ R has no effect on RBC sensitivity. RBC sensitivity normalized by the RBC sensitivity for WT mice in the dark and then graphed by background illumination and fit using a Weber-Fechner equation for WT mice with (purple) or without (black) intravitreal injection of gabazine.

5.2.2 D1R inhibition does not decrease RBC sensitivity in the absence of serial inhibition

As demonstrated in a previous chapter, inhibiting D1R pharmacologically causes a reduction in b-wave amplitude (Figures 5C and 15A) and RBC sensitivity (Figure 5D). If the D1R important for the sensitization is located on a cell upstream of the primary $GABA_A$ R-activating neuron, then blocking serial inhibition should rescue this D1R antagonist phenotype. The reduction in b-wave amplitude is, in fact, completely reversed (Figures 14 and 15A), with b-wave amplitude in the presence of both gabazine and the D1R antagonist even slightly higher than the amplitude in the presence of gabazine alone. Blocking D1R activity does not change RBC sensitivity in the absence of

serial inhibition (Figure 15D), suggesting that the D1R important for this mechanism is not located on the primary wide-field amacrine cell.

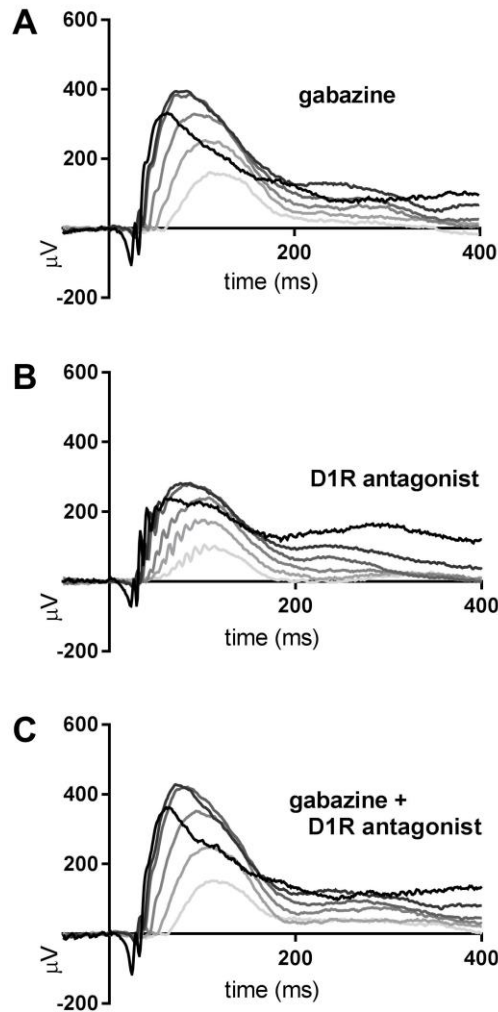

Figure 14: Responses to flashes in dark-adapted retinas after blocking serial inhibition or D1R activity. Representative traces from one eye of each condition in response to a series of flashes (at time = 0) from 0.2 to 670 R*/rod. Darker lines correspond to brighter flashes.

5.2.3 D1R activation increases b-wave amplitude independent of RBC sensitivity in the absence of serial inhibition

Interestingly, the D1R agonist did not have the opposite effect of the D1R antagonist under every condition. Although a previous study found that the D1R agonist SKF38393 paradoxically reduces b-wave amplitude and RBC sensitivity in the dark-adapted retina (Smith et al 2015), the D1R agonist SKF81297 was used here because, as a partial agonist (Watts et al 1993), SKF38393 could be inhibiting D1R depending on background dopamine levels. SKF81297 did not cause a reduction in b-wave amplitude (Figure 15B), and when serial inhibition was blocked by gabazine injection, SKF81297 caused an increase in b-wave amplitudes at brighter flashes (Figure 15B and Figure 16). The brightest flash pictured ($670 \text{ R}^*/\text{rod}$) is bright enough for the waveform to include a visible a-wave, which cuts into the absolute microvolts from baseline (μV) reached after gabazine injection (Figure 16A) but not in the presence of the D1R agonist (Figure 16B), greatly increasing the total b-wave amplitude comparatively. However, this increase in amplitude did not translate to a change in rod bipolar cell sensitivity (Figure 15D).

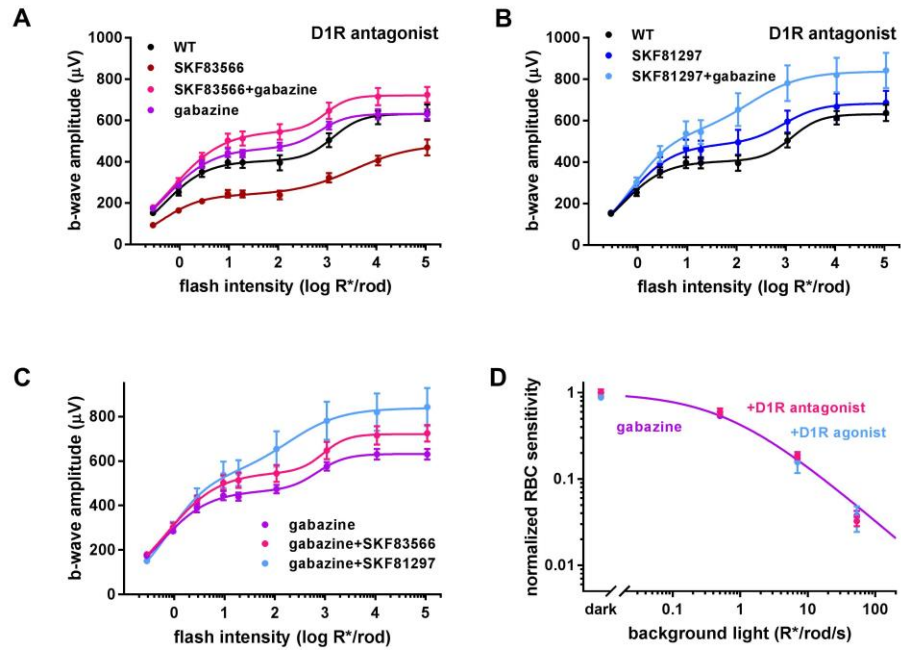

Figure 15: Effect of dopamine on RBC sensitivity and b-wave amplitudes in the absence of serial inhibition. A) The dark-adapted b-wave amplitudes of WT (black), D1R antagonist (red), GABA_A antagonist (purple), and D1R antagonist with GABA_A antagonist (pink). B) The dark-adapted b-wave amplitudes of D1R agonist (dark blue) and D1R agonist with GABA_A antagonist (light blue). C) The dark-adapted b-wave amplitudes from GABA_A antagonist (purple) with a D1 agonist (blue) or a D1 antagonist (pink). D) The RBC sensitivity data from the groups shown in C normalized to the dark-adapted RBC sensitivity in the presence of the GABA_A inhibitor and fit to a Weber-Fechner equation.

5.3 Conclusion

In this chapter, we showed that the dopamine D1 receptor important for rod bipolar cell sensitivity is not located on the wide-field amacrine that is responsible for the tonic GABA release that activates the GABA_C receptors. When serial inhibition is blocked, which isolates the final GABA-releasing cell from any larger GABA_AR based circuit, no manipulation of D1R activity influences RBC sensitivity. The effect of D1R

activation in the absence of serial inhibition is likely to be driven by an entirely different circuit.

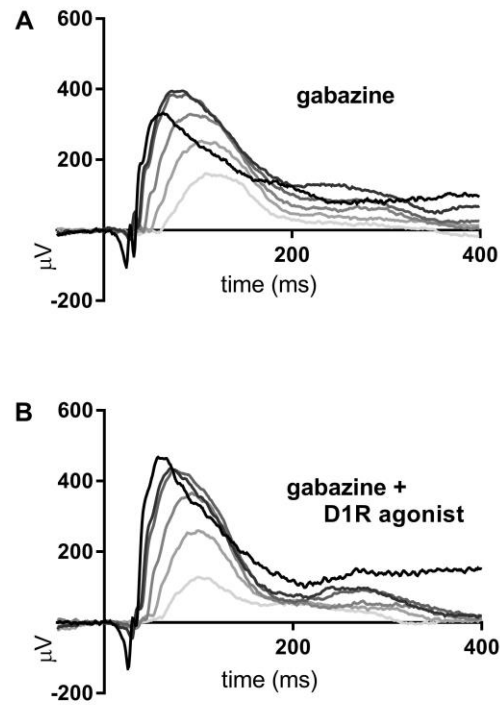

Figure 16: Responses to flashes in dark-adapted, serial inhibition-free retinas with or without a D1R agonist. Representative traces from one eye of each condition in response to a series of flashes (at time = 0) from 0.2 to 670 R^*/rod . Darker lines correspond to brighter flashes.

6. D1R expression in the retina

The data in the previous chapters suggests that there might be a population of wide-field amacrine cells that do not express D1R and a population of wide-field amacrine cells that do. D1R localization by immunostaining is not feasible for cells with extensive processes in the dense IPL, so D1R expression by wide-field amacrine cells has never been explored. In this chapter, we demonstrate that the many wide-field amacrine cell sub-types have specific but divergent levels of D1R expression.

6.1 Study background and objectives

To clarify cellular expression of the synaptic protein D1R, a mouse that expresses cytosolic β -galactosidase rather than D1R from the *Drd1a* gene locus was generated (Figure 3B). Recently, another model using a BAC transgenic technique to drive *Drd1a*-tdTomato was examined (Farshi et al 2016). With the caveat that BAC transgenic techniques carry more risk of altered reporter expression than homologous recombination, a lot of detailed information about D1R expression in cone bipolar cells has now been documented. The study also found that around 25% of AII amacrine cells express D1R without examining D1R expression in any other amacrine cell types.

Wide-field amacrine cells in general are still very poorly characterized, with expression of GABA synthesis or transportation machinery being some of the only marker for the population, and the membrane location of these markers is not ideal for clear soma colocalization. The transcription factor *Bhlhb5*, required for the specification

of many GABAergic neurons, is an incomplete but best available marker for wide-field amacrine somas (Feng et al 2006).

In this study, we examined D1R expression in the retina using a cytosolic β -galactosidase reporter to determine the extent of D1R expression in wide-field amacrine cells.

6.2 Results

6.2.1 D1R is expressed in a distinct subset of bipolar and amacrine cells

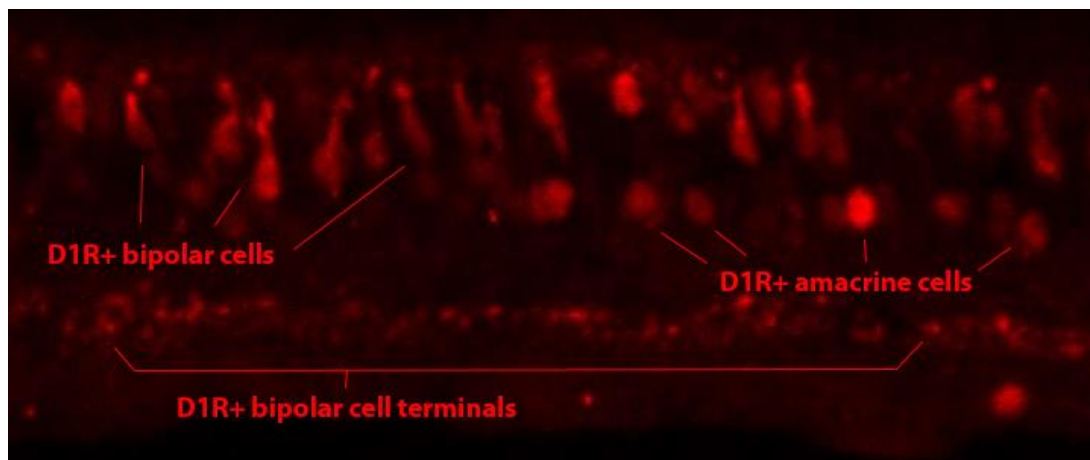

Figure 17: β -galactosidase expression in a tangential section of the $D1R^{\beta\text{-gal}/\beta\text{-gal}}$ retina. Tangential section through the retina with the OPL at the top, the ganglion cell layer at the bottom, and β -galactosidase staining in red.

The organization of the retina allows for easy identification of many cell types even without co-staining for other markers. As seen in a tangential section of a $D1R^{\beta\text{-gal}/\beta\text{-gal}}$ retina, the prominent cells with β -galactosidase expression in mice are a subset of cone bipolar cells with large, prominent axon terminals and a subset of amacrine cells (Figure

17). The cone bipolar expression matches data from BAC-driven D1R reporter expression (Farshi et al 2016).

In an image taken through the amacrine cell neuronal layer from a whole-mount D1R ^{β -gal/ β -gal} retina, there are visible axons running perpendicular to the image that are PKC α or β -gal positive (Figure 18). The lack of colocalization of β -galactosidase with PKC α confirms that rod bipolar cells do not express D1R. This is important confirmation, because expression of D1R in RBCs would complicate the ERG data. It might also be of interest that the commonly-studied starburst amacrine cells do not express D1R (Figure 19).

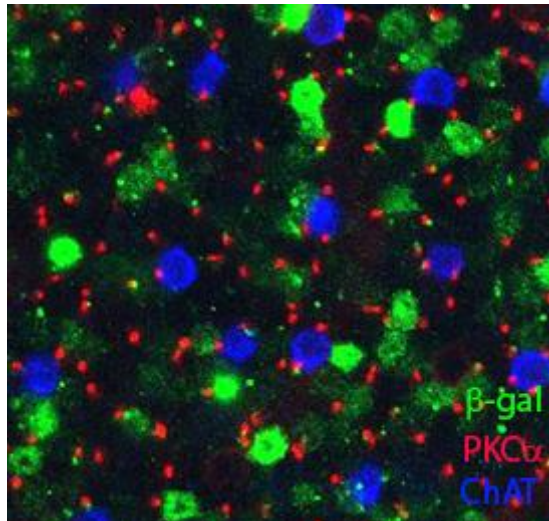

Figure 18: D1R is not expressed by rod bipolar or starburst amacrine cells. Image taken through the amacrine cell bodies in a D1R ^{β -gal/ β -gal} whole-mount retina. ChAT (blue) labels starburst amacrine cell bodies, PKC α (red) labels RBC axons, and β -galactosidase (green) labels both cell bodies and axons (diameter equivalent to the PKC α axons).

6.2.2 D1R is expressed in a subset of wide-field amacrine cells

Co-staining with the wide-field amacrine marker Bhlhb5 in either whole-mount retina at the level of the amacrine cell bodies (Figure 19) or in tangential sections (Figure 20) reveals 3 distinct populations of interest: (1) wide-field amacrine cells that do not express D1R, (2) non-wide-field amacrine cells that express D1R, and (3) wide-field amacrine cells that express D1R.

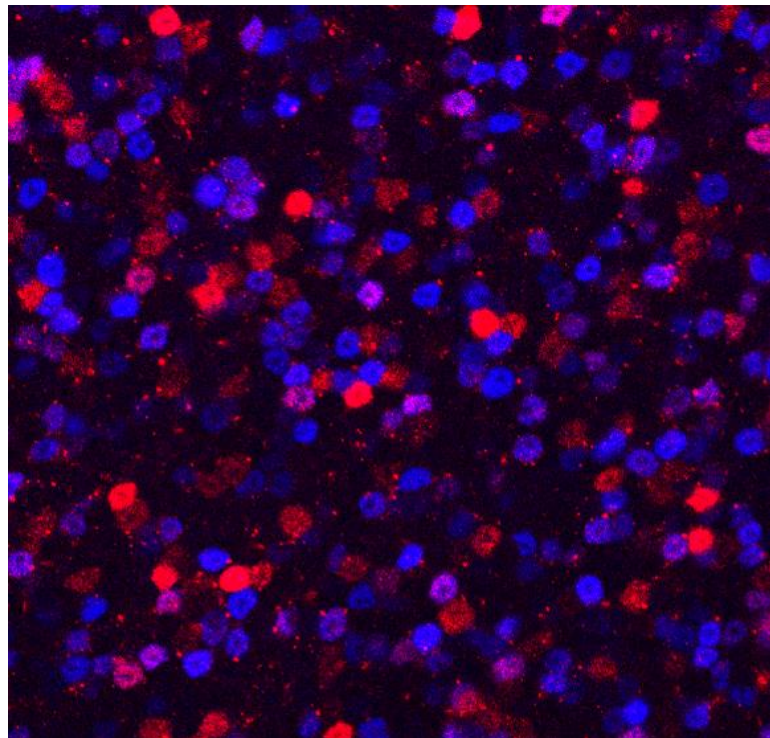

Figure 19: Retinal wholemount showing D1R+ wide-field amacrine cells. Image taken through the amacrine cell bodies in a D1R^{β-gal/β-gal} whole-mount retina. β-galactosidase (red) shows colocalization with a subset of wide-field amacrine cell bodies labeled with Bhlhb5 (blue).

It is also notable that the quantity of β -galactosidase varies significantly among the D1R+ cells. The stability of β -galactosidase is likely allowing a window into relative D1R expression—cells with higher levels of D1R expression have accumulated appreciably more β -galactosidase over time.

6.3 Conclusion

In this chapter, we showed that there are wide-field amacrine cells that express. Perhaps just as important for understanding the RBC sensitivity circuit, there are also wide-field amacrine cells that do not express D1R. This is one of the first demonstrations, though unsurprising, that the under classified wide-field amacrine cell population is not homogeneous.

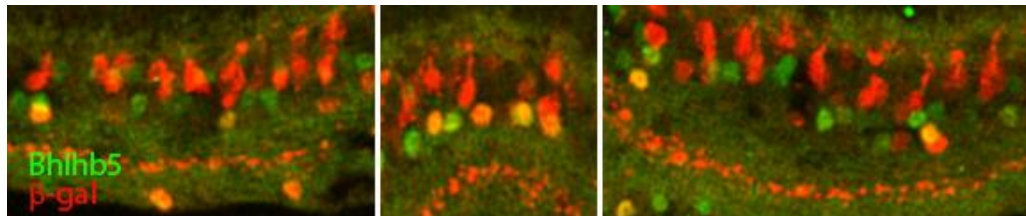

Figure 20: Tangential retinal sections showing D1R+ wide-field amacrine cells. β -galactosidase (red) shows colocalization with a subset of wide-field amacrine cell bodies labeled with Bhlhb5 (green).

7. Discussion

The primary aim of this dissertation was to define the circuit underlying rod bipolar cell sensitivity. RBC sensitivity was known to depend on GABA_cR and D1R, but the cellular source of the GABA release and the cellular location of the D1R were both unclear. The studies presented here confirm that it is a wide-field amacrine cell, not a horizontal cell, responsible for the sensitizing GABA release and that D1R inhibits serial inhibition via GABA_A receptors rather than directly enhancing GABA release onto the RBC GABA_c receptors (Figure 21). D1R activity is upstream of serial inhibition. In adding important genetic controls to eliminate horizontal cells and off-target effects of TTX, the findings here are mostly consistent with conclusions by Smith (Smith et al 2015, Smith et al 2013): the wide-field amacrine cell is the only possible cell which has TTX- and gabazine-sensitive GABA release onto RBC GABA_c receptors. The most interesting part of these results is what it means for regulation of the circuit.

7.1 Regulation of RBC resting potential by light

These ERG experiments test Weber contrast—ability to respond to brief flashes of light in the presence of a constant background. There is evidence that the rod system can respond to much brighter lights if the stimulus is instead coded with Michelson contrast—a change in intensity around the background rather than just above the background (Ke et al 2014). The rod system can differentiate low Michelson contrast in background light that renders Weber contrast unintelligible. This is due to the depletion

of the ready-releasable pool (RRP) of glutamate vesicles in the RBC terminal at the higher voltages in RBCs during background light. It is not until the pool can be replenished during a brief period of hyperpolarization during Michelson contrast that a slight increase in light above the background can be translated into an increase in glutamate release. Rather than being a readout of overall rod system function, then, measuring responses of RBCs to changes in Weber contrast, like the experiments in this dissertation, might be best classified as a readout of resting membrane voltage of the RBCs. A more negative resting potential is less susceptible to the RRP depletion that limits Weber contrast detection, so the deterioration of Weber contrast detection in the conditions that inhibit this RBC sensitization circuit (*GABACR^{-/-}*, *D1R^{-/-}*, TTX injection) indicate that it is the resting potential of the RBCs at any particular level of background light that is responsible.

The involvement of wide-field amacrine cells in this circuit defines a source of regulation for this resting potential. The chloride ion-dependent component of the rod bipolar cell hyperpolarization can be regulated by light levels in other parts of the retina via this wide-field amacrine cell, counteracting its own light-induced depolarization and extending its operating range. In uniform background light, the relationship between background light-induced depolarization at an individual RBC and the background light-induced GABA-based hyperpolarization are at a measurable equilibrium. It is likely that overall GABA input increases as background light increases (Chavez et al

2010), but as the data shows, this input can be regulated by serial inhibition and dopamine.

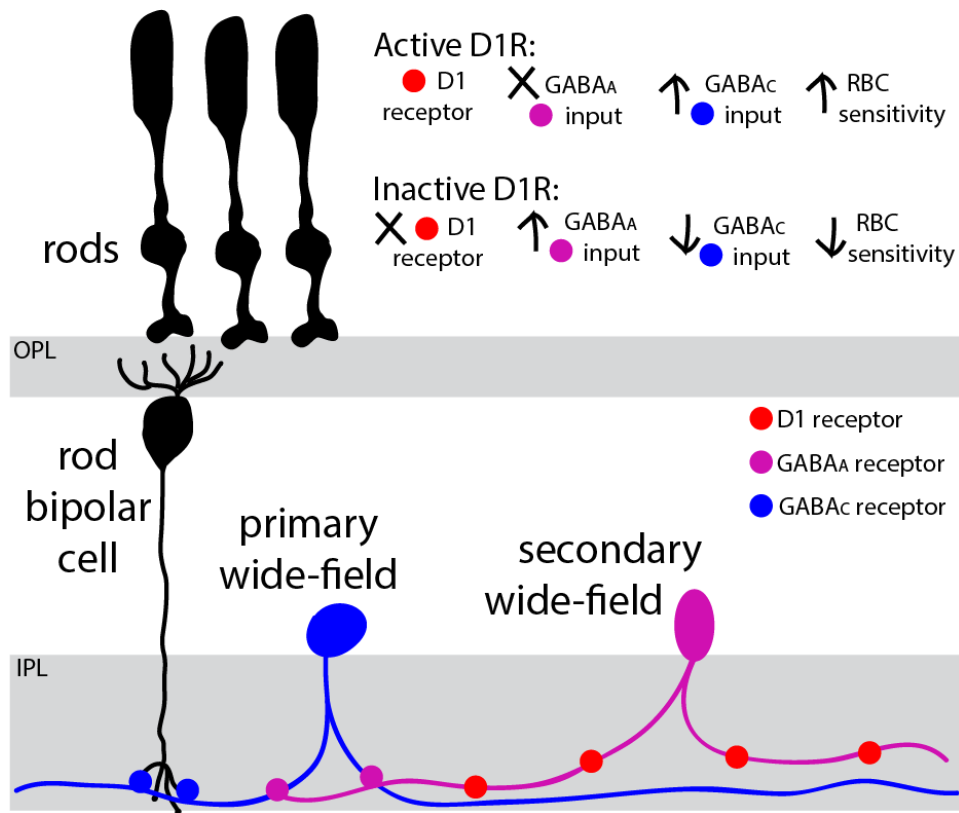

Figure 21: Model for the circuitry underlying RBC sensitivity.

D1R localized to a secondary wide-field inhibits release of GABA onto GABA_A receptors on the primary wide-field cell, allowing for GABA release from the primary wide-field amacrine cell onto the RBC. The open GABA_C receptors hyperpolarize the RBC and drive RBC sensitivity.

7.2 Regulation of RBC sensitivity through lateral signaling

The large slice of the retina that a wide-field amacrine cell can span (Lin & Masland 2006) is likely very important for the basic function of this mechanism in everyday vision. The relative amount of GABA released onto a rod bipolar cell would be a function of the average background light over a very significant percentage of the retina. With the prevalence of cell-cell coupling in the retina (Vaney 1991) and the involvement of serial inhibition, it could be even larger area than the already large receptive field for a single wide-field amacrine cell that influences GABA_c receptor activation at a rod bipolar cell. Under certain conditions, the GABA output from the final wide-field amacrine cell in the circuit might be representative of the average level of illumination in the entire visual field. This mechanism may optimize the adaptation of the rod system to the global conditions of overall illumination in the visual environment to eliminate any outsized influence on the response from localized light intensity fluctuations.

One of the limitations of full-field ERGs is that they do not allow the study of retinal processes that involve lateral transfer of non-balanced dynamic information. It is very possible that this circuit could be much more complicated than a simple read-out of the current level of background light.

7.3 Regulation of RBC sensitivity by dopamine

The precise role of dopamine in the regulation of this RBC sensitization mechanism remains an open question. Under our experimental conditions, serial inhibition has no impact on RBC sensitivity. This seems to indicate that, although D1R activity is totally essential for normal function, its precise role might be of passively, constantly increasing the activation threshold of the secondary amacrine cell too much to allow for serial inhibition to occur. D1R activity in the dark has the same impact on RBC sensitivity as D1R activity in the presence of background light, even though dopamine levels are very different during those two conditions. This passive role is likely an artifact of our method of data collection. We designed the experiments to be a read-out of very static conditions, and dopamine could have a much more dynamic role in natural dim-light vision. As a signal representative of total illumination in the retina, dopamine would be a good candidate to dynamically influence the rod bipolar cell sensitization circuit if there are sudden, large fluctuations in light level that the retina could disregard as abnormal by not adapting to the new average level of illumination as quickly. Slowing down adaptation could be beneficial.

There is some evidence that D1R is also working to inhibit rather than permit GABA input to rod bipolar cells (Eggers et al 2013, Smith et al 2015). This is a function for dopamine that has long been discussed, and at light levels where the rod system is no longer functional, direct inhibition of GABA release onto RBCs by D1R may occur.

However, in dim light, it is clear that the ultimate function of D1R is to indirectly allow for GABA release. One explanation could be that the primary wide-field amacrine responsible for the sensitizing GABA release does express D1R but at a level too low to impact GABA release outside of the high dopamine levels in bright light. Data here does indicate that wide-field amacrine cells show very different levels of D1R expression. However, D1R activity in the primary wide-field amacrine cell has no role in influencing RBC sensitization in dim light.

7.4 Future studies of the RBC sensitivity circuit

The most important next step in the investigation of this circuit is to develop the genetic tools to precisely identify the wide-field amacrine cell that is responsible for the GABA directly onto RBCs, as well the D1R-expressing amacrine cell that provides the serial inhibition. Monosynaptic circuit tracing using modified rabies virus, which has been successful in the retina (Wall et al 2010, Yonehara et al 2013), could confirm and define the morphology of these wide-field cells that have only been shown to exist using electrophysiology. Currently, sub-classification of wide-field amacrine cells has been limited mostly to morphological criteria (Lin & Masland 2006). It will be very important to start combining function and morphology for retinal interneurons. After that, detailed analysis of gene expression, like a recent study on bipolar cells (Shekhar et al 2016), could lead to targets for genetic manipulation of these cells. The retina provides a wonderful opportunity to dissect circuitry using the very precise input of light, but

genetic tools are needed in order to study the circuits in a way that allows for minimal disruption of the environment without sacrificing clarity about exactly how the circuit has been manipulated.

7.5 Conclusions

The circuit underlying rod bipolar cell sensitivity has been more clearly defined. We have shown that horizontal cells are not important for RBC sensitivity. Instead, tonic GABA input onto rod bipolar cells comes from a subpopulation of wide-field amacrine cells, and the circuit responsible for generating this GABA input is regulated by a dopamine D1 receptor-driven dampening of inhibitory input to this primary wide-field amacrine cell population. This circuit regulates the amplitude of dim light responses and, ultimately, extends the operational range of the rod-driven visual system.

References

- Arias-Montano JA, Floran B, Floran L, Aceves J, Young JM. 2007. Dopamine D(1) receptor facilitation of depolarization-induced release of gamma-amino-butyric acid in rat striatum is mediated by the cAMP/PKA pathway and involves P/Q-type calcium channels. *Synapse* 61: 310-9
- Arshavsky VY, Burns ME. 2014. Current understanding of signal amplification in phototransduction. *Cell Logist* 4: e29390
- Behrens C, Schubert T, Haverkamp S, Euler T, Berens P. 2016. Connectivity map of bipolar cells and photoreceptors in the mouse retina. *Elife* 5
- Birch DG, Fish GE. 1987. Rod ERGs in retinitis pigmentosa and cone-rod degeneration. *Invest Ophthalmol Vis Sci* 28: 140-50
- Bowmaker JK, Dartnall HJ. 1980. Visual pigments of rods and cones in a human retina. *J Physiol* 298: 501-11
- Breton ME, Schueller AW, Lamb TD, Pugh EN, Jr. 1994. Analysis of ERG a-wave amplification and kinetics in terms of the G-protein cascade of phototransduction. *Invest Ophthalmol Vis Sci* 35: 295-309
- Cangiano L, Gargini C, Della Santina L, Demontis GC, Cervetto L. 2007. High-pass filtering of input signals by the I_h current in a non-spiking neuron, the retinal rod bipolar cell. *PLoS One* 2: e1327
- Chavez AE, Grimes WN, Diamond JS. 2010. Mechanisms underlying lateral GABAergic feedback onto rod bipolar cells in rat retina. *J Neurosci* 30: 2330-9
- Chavez AE, Singer JH, Diamond JS. 2006. Fast neurotransmitter release triggered by Ca influx through AMPA-type glutamate receptors. *Nature* 443: 705-8
- Demb JB, Singer JH. 2012. Intrinsic properties and functional circuitry of the AII amacrine cell. *Vis Neurosci* 29: 51-60
- Deniz S, Wersinger E, Schwab Y, Mura C, Erdelyi F, et al. 2011. Mammalian retinal horizontal cells are unconventional GABAergic neurons. *J Neurochem* 116: 350-62

- Dong CJ, Hare WA. 2003. Temporal modulation of scotopic visual signals by A17 amacrine cells in mammalian retina in vivo. *J Neurophysiol* 89: 2159-66
- Doyle SE, McIvor WE, Menaker M. 2002. Circadian rhythmicity in dopamine content of mammalian retina: role of the photoreceptors. *J Neurochem* 83: 211-9
- Eggers ED, Lukasiewicz PD. 2006a. GABA(A), GABA(C) and glycine receptor-mediated inhibition differentially affects light-evoked signalling from mouse retinal rod bipolar cells. *J Physiol* 572: 215-25
- Eggers ED, Lukasiewicz PD. 2006b. Receptor and transmitter release properties set the time course of retinal inhibition. *J Neurosci* 26: 9413-25
- Eggers ED, Lukasiewicz PD. 2010. Interneuron circuits tune inhibition in retinal bipolar cells. *J Neurophysiol* 103: 25-37
- Eggers ED, Mazade RE, Klein JS. 2013. Inhibition to retinal rod bipolar cells is regulated by light levels. *J Neurophysiol* 110: 153-61
- Euler T, Masland RH. 2000. Light-evoked responses of bipolar cells in a mammalian retina. *J Neurophysiol* 83: 1817-29
- Farshi P, Fyk-Kolodziej B, Krolewski DM, Walker PD, Ichinose T. 2016. Dopamine D1 receptor expression is bipolar cell type-specific in the mouse retina. *J Comp Neurol* 524: 2059-79
- Feng L, Xie X, Joshi PS, Yang Z, Shibasaki K, et al. 2006. Requirement for Bhlhb5 in the specification of amacrine and cone bipolar subtypes in mouse retina. *Development* 133: 4815-25
- Grimes WN, Zhang J, Tian H, Graydon CW, Hoon M, et al. 2015. Complex inhibitory microcircuitry regulates retinal signaling near visual threshold. *J Neurophysiol* 114: 341-53
- Hampson EC, Vaney DI, Weiler R. 1992. Dopaminergic modulation of gap junction permeability between amacrine cells in mammalian retina. *J Neurosci* 12: 4911-22
- Hayashida Y, Rodriguez CV, Ogata G, Partida GJ, Oi H, et al. 2009. Inhibition of adult rat retinal ganglion cells by D1-type dopamine receptor activation. *J Neurosci* 29: 15001-16

- Herrmann R, Heflin SJ, Hammond T, Lee B, Wang J, et al. 2011. Rod vision is controlled by dopamine-dependent sensitization of rod bipolar cells by GABA. *Neuron* 72: 101-10
- Hetling JR, Pepperberg DR. 1999. Sensitivity and kinetics of mouse rod flash responses determined in vivo from paired-flash electroretinograms. *J Physiol* 516 (Pt 2): 593-609
- Hirano AA, Liu X, Boulter J, Grove J, Perez de Sevilla Muller L, et al. 2016. Targeted Deletion of Vesicular GABA Transporter from Retinal Horizontal Cells Eliminates Feedback Modulation of Photoreceptor Calcium Channels. *eNeuro* 3
- Ichinose T, Lukasiewicz PD. 2007. Ambient light regulates sodium channel activity to dynamically control retinal signaling. *J Neurosci* 27: 4756-64
- Iuvone PM, Galli CL, Garrison-Gund CK, Neff NH. 1978. Light stimulates tyrosine hydroxylase activity and dopamine synthesis in retinal amacrine neurons. *Science* 202: 901-2
- Jackson CR, Ruan GX, Aseem F, Abey J, Gamble K, et al. 2012. Retinal dopamine mediates multiple dimensions of light-adapted vision. *J Neurosci* 32: 9359-68
- Kay JN, Voinescu PE, Chu MW, Sanes JR. 2011. Neurod6 expression defines new retinal amacrine cell subtypes and regulates their fate. *Nat Neurosci* 14: 965-72
- Ke JB, Wang YV, Borghuis BG, Cembrowski MS, Rieke H, et al. 2014. Adaptation to background light enables contrast coding at rod bipolar cell synapses. *Neuron* 81: 388-401
- Koike C, Obara T, Uriu Y, Numata T, Sanuki R, et al. 2010. TRPM1 is a component of the retinal ON bipolar cell transduction channel in the mGluR6 cascade. *Proc Natl Acad Sci U S A* 107: 332-7
- Kolb H. 1974. The connections between horizontal cells and photoreceptors in the retina of the cat: electron microscopy of Golgi preparations. *J Comp Neurol* 155: 1-14
- Kolb H. 1991. Anatomical pathways for color vision in the human retina. *Vis Neurosci* 7: 61-74

- Kothmann WW, Massey SC, O'Brien J. 2009. Dopamine-stimulated dephosphorylation of connexin 36 mediates AII amacrine cell uncoupling. *J Neurosci* 29: 14903-11
- Lin B, Masland RH. 2006. Populations of wide-field amacrine cells in the mouse retina. *J Comp Neurol* 499: 797-809
- Liu X, Grove JC, Hirano AA, Brecha NC, Barnes S. 2016. Dopamine D1 receptor modulation of calcium channel currents in horizontal cells of mouse retina. *J Neurophysiol* 116: 686-97
- MacNeil MA, Heussy JK, Dacheux RF, Raviola E, Masland RH. 1999. The shapes and numbers of amacrine cells: matching of photofilled with Golgi-stained cells in the rabbit retina and comparison with other mammalian species. *J Comp Neurol* 413: 305-26
- Masland RH. 2012. The neuronal organization of the retina. *Neuron* 76: 266-80
- Matthews G, Fuchs P. 2010. The diverse roles of ribbon synapses in sensory neurotransmission. *Nat Rev Neurosci* 11: 812-22
- McCall MA, Gregg RG. 2008. Comparisons of structural and functional abnormalities in mouse b-wave mutants. *J Physiol* 586: 4385-92
- McCall MA, Lukasiewicz PD, Gregg RG, Peachey NS. 2002. Elimination of the rho1 subunit abolishes GABA(C) receptor expression and alters visual processing in the mouse retina. *J Neurosci* 22: 4163-74
- McMahon DG, Knapp AG, Dowling JE. 1989. Horizontal cell gap junctions: single-channel conductance and modulation by dopamine. *Proc Natl Acad Sci U S A* 86: 7639-43
- Mills SL, Xia XB, Hoshi H, Firth SI, Rice ME, et al. 2007. Dopaminergic modulation of tracer coupling in a ganglion-amacrine cell network. *Vis Neurosci* 24: 593-608
- Nelson R, Kolb H. 1983. Synaptic patterns and response properties of bipolar and ganglion cells in the cat retina. *Vision Res* 23: 1183-95
- Nikonov SS, Kholodenko R, Lem J, Pugh EN, Jr. 2006. Physiological features of the S- and M-cone photoreceptors of wild-type mice from single-cell recordings. *J Gen Physiol* 127: 359-74

- Ogata G, Stradleigh TW, Partida GJ, Ishida AT. 2012. Dopamine and full-field illumination activate D1 and D2-D5-type receptors in adult rat retinal ganglion cells. *J Comp Neurol* 520: 4032-49
- Podda MV, Riccardi E, D'Ascenzo M, Azzena GB, Grassi C. 2010. Dopamine D1-like receptor activation depolarizes medium spiny neurons of the mouse nucleus accumbens by inhibiting inwardly rectifying K⁺ currents through a cAMP-dependent protein kinase A-independent mechanism. *Neuroscience* 167: 678-90
- Robson JG, Frishman LJ. 1998. Dissecting the dark-adapted electroretinogram. *Doc Ophthalmol* 95: 187-215
- Robson JG, Maeda H, Saszik SM, Frishman LJ. 2004. In vivo studies of signaling in rod pathways of the mouse using the electroretinogram. *Vision Res* 44: 3253-68
- Rodieck RW. 1998. *The first steps in seeing*. Sunderland, Mass.: Sinauer Associates. xi, 562 p. pp.
- Shekhar K, Lapan SW, Whitney IE, Tran NM, Macosko EZ, et al. 2016. Comprehensive Classification of Retinal Bipolar Neurons by Single-Cell Transcriptomics. *Cell* 166: 1308-23 e30
- Shields CR, Lukasiewicz PD. 2003. Spike-dependent GABA inputs to bipolar cell axon terminals contribute to lateral inhibition of retinal ganglion cells. *J Neurophysiol* 89: 2449-58
- Smith BJ, Cote PD, Tremblay F. 2015. Dopamine modulation of rod pathway signaling by suppression of GABAC feedback to rod-driven depolarizing bipolar cells. *Eur J Neurosci* 42: 2258-70
- Smith BJ, Tremblay F, Cote PD. 2013. Voltage-gated sodium channels contribute to the b-wave of the rodent electroretinogram by mediating input to rod bipolar cell GABA(c) receptors. *Exp Eye Res* 116: 279-90
- Tessier-Lavigne M, Attwell D, Mobbs P, Wilson M. 1988. Membrane currents in retinal bipolar cells of the axolotl. *J Gen Physiol* 91: 49-72
- Trumpler J, Dedek K, Schubert T, de Sevilla Muller LP, Seeliger M, et al. 2008. Rod and cone contributions to horizontal cell light responses in the mouse retina. *J Neurosci* 28: 6818-25

- Tsukamoto Y, Omi N. 2013. Functional allocation of synaptic contacts in microcircuits from rods via rod bipolar to AII amacrine cells in the mouse retina. *J Comp Neurol* 521: 3541-55
- Vaney DI. 1991. Many diverse types of retinal neurons show tracer coupling when injected with biocytin or Neurobiotin. *Neurosci Lett* 125: 187-90
- Veruki ML. 1997. Dopaminergic neurons in the rat retina express dopamine D2/3 receptors. *Eur J Neurosci* 9: 1096-100
- Volgyi B, Chheda S, Bloomfield SA. 2009. Tracer coupling patterns of the ganglion cell subtypes in the mouse retina. *J Comp Neurol* 512: 664-87
- Vu TQ, Payne JA, Copenhagen DR. 2000. Localization and developmental expression patterns of the neuronal K-Cl cotransporter (KCC2) in the rat retina. *J Neurosci* 20: 1414-23
- Wachtmeister L. 1998. Oscillatory potentials in the retina: what do they reveal. *Prog Retin Eye Res* 17: 485-521
- Wall NR, Wickersham IR, Cetin A, De La Parra M, Callaway EM. 2010. Monosynaptic circuit tracing in vivo through Cre-dependent targeting and complementation of modified rabies virus. *Proc Natl Acad Sci U S A* 107: 21848-53
- Wang Y, Harsanyi K, Mangel SC. 1997. Endogenous activation of dopamine D2 receptors regulates dopamine release in the fish retina. *J Neurophysiol* 78: 439-49
- Watts VJ, Lawler CP, Gilmore JH, Southerland SB, Nichols DE, Mailman RB. 1993. Dopamine D1 receptors: efficacy of full (dihydroxidine) vs. partial (SKF38393) agonists in primates vs. rodents. *Eur J Pharmacol* 242: 165-72
- Weiler R, Pottel M, He S, Vaney DI. 2000. Modulation of coupling between retinal horizontal cells by retinoic acid and endogenous dopamine. *Brain Res Brain Res Rev* 32: 121-9
- Yonehara K, Balint K, Noda M, Nagel G, Bamberg E, Roska B. 2011. Spatially asymmetric reorganization of inhibition establishes a motion-sensitive circuit. *Nature* 469: 407-10

Yonehara K, Farrow K, Ghanem A, Hillier D, Balint K, et al. 2013. The first stage of cardinal direction selectivity is localized to the dendrites of retinal ganglion cells. *Neuron* 79: 1078-85

Biography

Amanda Travis was born in Fredericksburg, VA, on January 29, 1984, and raised in Parker, CO. She attended the University of Colorado at Boulder and graduated *magna cum laude* with a bachelor's degree in Molecular, Cellular, and Developmental Biology and a minor in Biochemistry in May 2008.