

ORIGINAL ARTICLE

# *In Vitro* Fluid Dynamics of the Ahmed Glaucoma Valve Modified with Expanded Polytetrafluoroethylene

Francis Char DeCroos<sup>1</sup>, Yuji Kondo<sup>1,2</sup>, Daniel Mordes<sup>2</sup>, Maria Regina Lee<sup>2</sup>, Sameer Ahmad<sup>1</sup>, Sanjay Asrani<sup>1</sup>, R. Rand Allingham<sup>1</sup>, Kevin C. Olbrich<sup>2</sup>, and Bruce Klitzman<sup>2</sup>

<sup>1</sup>Department of Ophthalmology, Duke University Medical Center, Durham, North Carolina, USA

<sup>2</sup>Kenan Plastic Surgery Research Labs, Department of Biomedical Engineering, Duke University Medical Center, Durham, North Carolina, USA

## ABSTRACT

**Purpose:** Long-term intraocular pressure reduction by glaucoma drainage devices (GDDs) is often limited by the fibrotic capsule that forms around them. Prior work demonstrates that modifying a GDD with a porous membrane promotes a vascularized and more permeable capsule. This work examines the *in vitro* fluid dynamics of the Ahmed valve after enclosing the outflow tract with a porous membrane of expanded polytetrafluoroethylene (ePTFE).

**Materials and Methods:** The control and modified Ahmed implants (termed porous retrofitted implant with modified enclosure or PRIME-Ahmed) were submerged in saline and gelatin and perfused in a system that monitored flow (Q) and pressure (P). Flow rates of 1–50  $\mu\text{l}/\text{min}$  were applied and steady state pressure recorded. Resistance was calculated by dividing pressure by flow.

**Results:** Modifying the Ahmed valve implant outflow with expanded ePTFE increased pressure and resistance. Pressure at a flow of 2  $\mu\text{l}/\text{min}$  was increased in the PRIME-Ahmed ( $11.6 \pm 1.5$  mm Hg) relative to the control implant ( $6.5 \pm 1.2$  mm Hg). Resistance at a flow of 2  $\mu\text{l}/\text{min}$  was increased in the PRIME-Ahmed ( $5.8 \pm 0.8$  mm Hg/ $\mu\text{l}/\text{min}$ ) when compared to the control implant ( $3.2 \pm 0.6$  mm Hg/ $\mu\text{l}/\text{min}$ ).

**Conclusions:** Modifying the outflow tract of the Ahmed valve with a porous membrane adds resistance that decreases with increasing flow. The Ahmed valve implant behaves as a variable resistor. It is partially open at low pressures and provides reduced resistance at physiologic flow rates.

**KEYWORDS:** Ahmed valve; Expanded polytetrafluoroethylene; Fluid dynamics; Foreign body response; Glaucoma implant

## INTRODUCTION

Glaucoma drainage devices (GDDs) are being used more frequently for glaucoma that is refractory to medications, laser surgery, and conventional filtration surgery. The GDDs shunt aqueous humor from

the anterior chamber through a silicone conduit to a reservoir implanted in the sub-Tenon's space at the equatorial region of the globe.<sup>1</sup> GDD implants generally demonstrate success rates comparable to trabeculectomy.<sup>2–5</sup>

The Ahmed glaucoma valve is one such GDD, yet considerable room exists for improving its long-term efficacy.<sup>6</sup> Though earlier causes of GDD failure vary and include hypotony,<sup>7</sup> a hypertensive phase,<sup>8</sup> and rarely failure of the valve mechanism,<sup>9</sup> the predominant cause of long-term GDD failure is the development of an impermeable tissue capsule around the

Received 27 April 2010; accepted 25 July 2010

Dr. Kondo's current address is Department of Ophthalmology, Gifu University School of Medicine, Gifu, Japan.

Correspondence: Bruce Klitzman, Ph.D., Box 3906, Duke University Medical Center, Durham, NC 27710. E-mail: klitz@duke.edu

GDD outflow reservoir.<sup>10-13</sup> This encapsulation reaction is similar to the tissue response observed around most polymer implants.<sup>14,15</sup> Fibrotic, minimally vascular capsule formation gradually increases outflow resistance from the drain and eventually results in increased intraocular pressure (IOP).

The encapsulation process is characterized by a chronic inflammatory response, often with the presence of foreign body giant cells.<sup>11,16</sup> Previous work has well established that a fibrous capsule impedes mass transport of fluid to and from implanted devices.<sup>17-19</sup> Though the preponderance of groups report no relative improvement in IOP control when using anti-metabolites during GDD implantation,<sup>20-24</sup> another study employed both postoperative and extended duration (mean 7.3–7.4 min) intraoperative anti-metabolite usage in conjunction with GDD implantation. This group demonstrated improved long-term IOP control rates, possibly through retardation of fibrotic capsule formation.<sup>25</sup>

The fibrotic foreign body tissue response can also be altered by material morphology alone and without pharmacologic intervention, thus avoiding the need for periodic drug delivery around the eye. Certain materials with defined porous microstructure are known to induce a vascular encapsulation response when implanted.<sup>18,19,26</sup> Combining these materials with a GDD to promote formation of a disorganized, highly vascular tissue adjacent to the implant instead of the usual dense capsule may be a novel way to improve long-term IOP control. Expanded ePTFE is one such material that alters foreign body tissue response when implanted.

Our group has developed a prototype Ahmed implant enclosed in a membrane of ePTFE, termed porous retrofitted implant with modified enclosure or PRIME-Ahmed (Figure 1). Prior work demonstrated that PRIME-Ahmed implanted into the rabbit eye

stimulates a thinner fibrous capsule and increased surrounding vascularity compared to implanted unmodified Ahmed valve.<sup>27</sup> The thinner, more vascular capsule promoted by the PRIME-Ahmed may improve long-term absorption of aqueous fluid through decreased resistance to fluid flow *in vivo*.

However, enclosing an outflow tract with ePTFE is a significant concern as it adds an unknown amount of resistance serially. Modifying the Ahmed outflow with ePTFE could increase the outflow resistance to such a large extent that this material would not constitute a viable shunt design. Therefore, the purpose of this study was to quantify the outflow resistances of both the standard Ahmed and the PRIME-Ahmed under a range of flow rates to determine its potential for use in a novel glaucoma shunt design.

## MATERIALS AND METHODS

### Modified Implant (PRIME-Ahmed) Creation

Fourteen Ahmed™ glaucoma valves Model S3 (pediatric Ahmed glaucoma valve implant, New World Medical, Rancho Cucamonga, California, USA) were utilized as control implants. Another fourteen pediatric Ahmed glaucoma Model S3 valve implants (termed porous retrofitted implant with modified enclosure or PRIME-Ahmed) were modified with a porous membrane as described previously (Figure 1).<sup>27</sup> Briefly, the outflow tract was enclosed by a bilayer of ePTFE (TheraCyte, Irvine, California, USA). The pediatric Model S3 was chosen as it allows implantation into a small mammal animal model allowing for *in vivo* investigations in a prior study.<sup>27</sup>

### Removal of Air Nuclei

In its native state, ePTFE contains approximately 70% air by volume<sup>28</sup> because the polymer is hydrophobic and resists wetting. Air nuclei occupy the spaces between fibers, obstructing the pores and providing significant resistance to flow. Priming the modified glaucoma drainage device with saline is insufficient to remove these air nuclei. While priming can forcibly wet some of the surfaces, scanning electron micrographs show that this process enlarges relatively few pores to create low resistance paths through the material while leaving most of the porous structure unchanged. Removal of the air nuclei, termed denucleation,<sup>29</sup> can be accomplished with over 90% efficacy by using low surface tension fluids, such as acetone or alcohol.<sup>28</sup> This will allow the pores to wet and the outflow resistance of the material will decrease markedly. Immersion in acetone

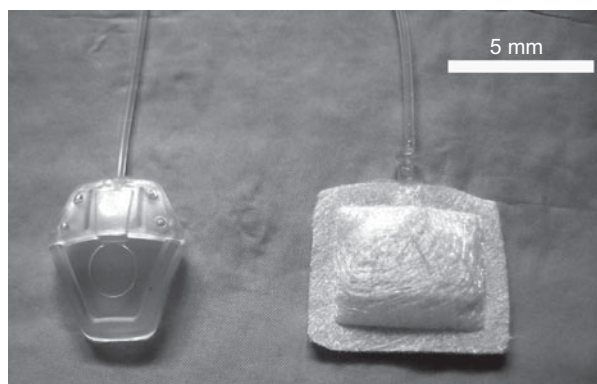

FIGURE 1 The ahmed glaucoma valve implant (left) outflow tract is modified with eptfe to create the prime-ahmed glaucoma valve (right).

and ethanol has been reported to denucleate ePTFE to different degrees.<sup>28,30</sup> For ease of experimentation, we initially denucleated the implants in 100% ethanol without vacuum for 60 min. However, we observed a further 30–40% ( $p < 0.05$ ) decrease in resistance when denucleating the implant by immersing in 100% ethanol under vacuum of 0.5 atmospheres for 60 min. This method has previously been shown to provide approximately 95% denucleation.<sup>28</sup> We denucleated both the 14 AGV implants and the 14 integrated implants to ensure consistency of experimental technique. After denucleation, the ethanol was replaced by soaking and thoroughly flushing the implants with saline.

### Pressure Testing: Saline and Gelatin

A micro-manometric apparatus was assembled for testing of the implant as described earlier.<sup>31</sup> Briefly, a pressure transducer (Model DP15-36, Validyne Engineering Corporation, Northridge, California, USA) was connected to a pressure monitor (Model CD379-1-2, Validyne Engineering Corporation). The manufacturer reports the DP 15-36 pressure transducer to be accurate to plus or minus 0.65 mm Hg. A mercury manometer and an adjustable electronic syringe pump (MD-1001, Bioanalytical Systems Inc., W. Lafayette, Indiana, USA) were also attached to the system. Fifty centimeters of polyethylene tubing (PE-50; Becton Dickinson Diagnostic Systems, Sparks, Maryland) connected the syringe pump to a T-junction. One end of this junction connected to a 27-gauge cannula placed in the anterior end of the implant tube. The other end of the junction connected to the pressure transducer and recorder (see Figure 2). The system was then flushed and calibrated with a mercury manometer.

Initially the implant was closed, so saline was perfused manually through the implant before connecting

to the apparatus. This is analogous to “priming” the implant in surgery prior to implantation. Prior to manual perfusion, the valve opening pressure exceeded the 200 mm Hg maximal range of our manometer. Valve opening was confirmed visually. Our experiments were conducted in both saline and 2.5% gelatin. Saline should provide negligible outflow resistance beyond the device compared to 2.5% gelatin, which should provide significant resistance to outflow beyond the device.

Each implant device was immersed in saline or 2.5% gelatin and the height of the transducer was adjusted to the same height as the height of the implant. Flow rates of 1, 2, 3, 5, 10, 20, and 50  $\mu\text{l}/\text{min}$  were used.

In order to minimize system artifacts, normalized steady-state pressure readings were recorded only beginning 15 min after starting the syringe pump. Flow resistance data was calculated from normalized pressure readings as described below.

### Fluid Dynamics and Statistical Analysis

In this study, steady state pressures were measured at various flow rates (1–50  $\mu\text{l}/\text{min}$ ). Although the flow rate of 2  $\mu\text{l}/\text{min}$  approximates the rate of aqueous drainage in human eyes and is well within our examined range,<sup>32</sup> we included a very broad range of flows that could be encountered in both normal and pathologic states. Resistance for each flow rate was calculated using mean steady state pressure recordings using the equation:  $Q = \Delta P/R$  where  $Q$  = flow ( $\mu\text{l}/\text{min}$ ),  $\Delta P$  = difference in pressure (mm Hg) between the T-connector (where the tubing branched to the drainage device) and the atmosphere, and  $R$  = resistance (mm Hg/ $\mu\text{l}/\text{min}$ ). At the flow rates used, the polyethylene tubing had negligible resistance as determined by removing the drainage device.

The Mann-Whitney U test was utilized to analyze differences in pressure within each experimental group (unmodified Ahmed glaucoma valve implant and PRIME-Ahmed, respectively) and between each experimental group.

## RESULTS

Seven denucleated S3 Ahmed glaucoma valve implants and seven denucleated S3 PRIME-Ahmed implants were assessed in saline at a variety of flow rates. Denucleation significantly reduced outflow resistance in the PRIME-Ahmed group (data not shown). For both implants across the range of tested flow rates, pressure increased more slowly (Figure 3A) and resistance decreased (Figure 3B) with increasing flow. This confirms that the valve is functioning as designed; that is, opening as flow increases. The

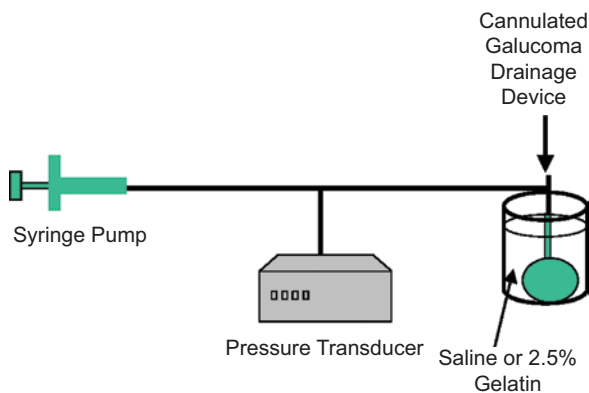

FIGURE 2 Glaucoma drainage device testing apparatus. An electronic syringe pump pressed fluid into the system at a constant flow rate. A pressure transducer constantly monitored pressure and values were recorded manually.

PRIME-Ahmed implants demonstrated increased pressure and resistance relative to the AGV implant at each flow rate (Figures 3A and 3B). Significant differences were noted at flow rates of 1, 3, 5, 10, 20, and 50  $\mu\text{L}/\text{min}$  ( $p < 0.05$ ).

In addition to the 14 implants tested in saline, seven S3 Ahmed glaucoma valve implants and seven PRIME-Ahmed implants were assessed in 2.5% gelatin at a variety of flow rates. For both implants across the range of tested flow rates, pressure increased and resistance decreased with increasing flow (Figures 4A and 4B). Similar to the results when tested in saline, the pressure increased steeply at low flow rates and then increased with a shallower slope at higher flows (Figure 4A). The resistance was higher at low flows and decreased rapidly as flow increased (Figure 4B). The PRIME-Ahmed implants demonstrated increased pressure and resistance relative to the AGV implant at most flow rates. Significant differences were noted at flow rates of 3, 5, 10, and 50  $\mu\text{L}/\text{min}$  ( $p < 0.05$ ).

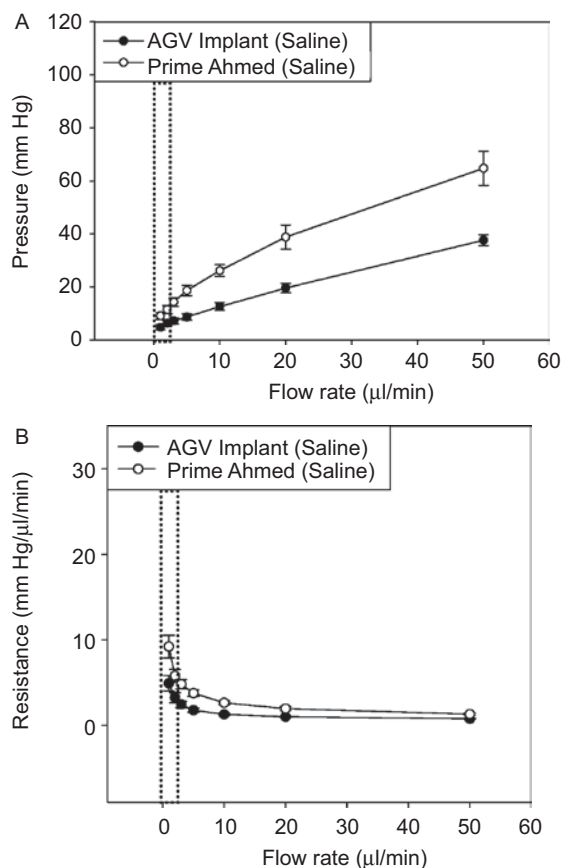

FIGURE 3 (A) Pressure versus flow in saline comparison of S3 Ahmed glaucoma valves (AGV) and PRIME-Ahmed implants. The physiologic flow range (0–2  $\mu\text{L}/\text{min}$ ) is demarcated by dashes, (B) Resistance versus flow in saline comparison of S3 Ahmed glaucoma valve (AGV) and PRIME-Ahmed implants. The physiologic flow range (0–2  $\mu\text{L}/\text{min}$ ) is demarcated by dashes.

As predicted, all the implants tested in 2.5% gelatin demonstrated greater pressure and resistance relative to implants tested in saline for each flow rate. While the absolute magnitude of each pressure or resistance value is greater for a particular flow rate, the overall shape of the graph is similar between the saline and gelatin groups. For the S3 Ahmed glaucoma valve implant group, significant differences existed between the saline and 2.5% gelatin groups for all seven tested flow rates ( $p < 0.05$ ). For the PRIME-Ahmed implant group, significant differences existed between the saline and 2.5% gelatin groups at flow rates of 2, 3, 5, 10, and 50  $\mu\text{L}/\text{min}$  ( $p < 0.05$ ).

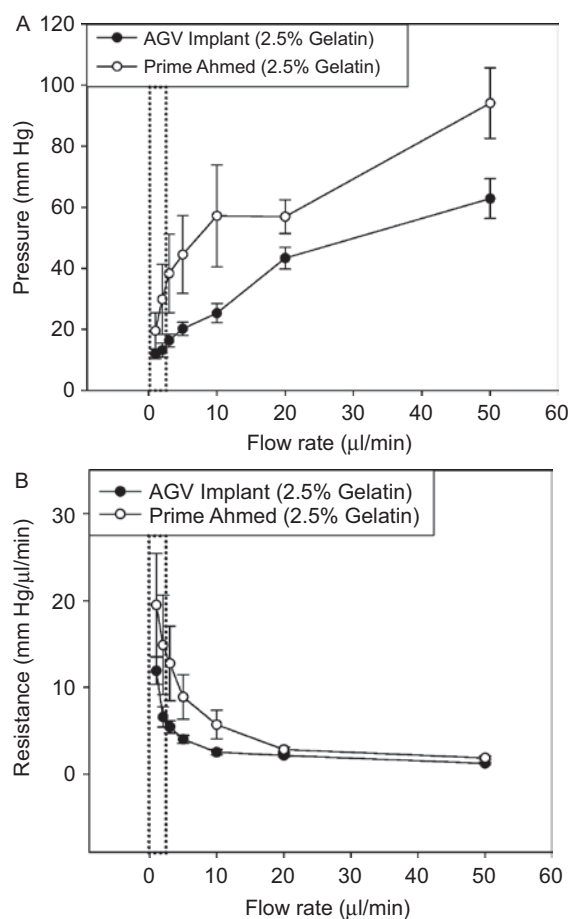

FIGURE 4 (A) Pressure versus flow in 2.5% gelatin comparison of S3 Ahmed glaucoma valves (AGV) and PRIME-Ahmed implants. The physiologic flow range (0–2  $\mu\text{L}/\text{min}$ ) is demarcated by dashes, (B) Resistance versus flow in 2.5% gelatin comparison of S3 Ahmed glaucoma valve implant (AGV) and PRIME-Ahmed implants. The physiologic flow range (0–2  $\mu\text{L}/\text{min}$ ) is demarcated by dashes.

## DISCUSSION

Beginning several weeks after GDD implantation, a fibrous capsule typically forms. As the capsule matures, the fibrosis induced by the foreign body reaction leads to increased outflow resistance of the GDD, possibly reducing outflow over time. Modifying the relatively avascular, fibrotic capsule may be instrumental in improving long-term implant viability. Prior work from our group demonstrated that the PRIME-Ahmed promoted a thinner fibrous capsule and increased vascularity adjacent to the implant when compared to unmodified Ahmed valves implanted in rabbits ( $46.4 \pm 10.8 \mu\text{m}$  versus  $94.9 \pm 21.2 \mu\text{m}$ ,  $p < 0.001$ ).<sup>27</sup> A thinner, more vascular capsule may decrease outflow resistance *in vivo* significantly enough to improve long-term intra-ocular pressure control. However, prior to implantation and *in vivo* study, it is important to assess how much serial resistance is added by porous membrane enclosure of a GDD outflow tract. If our prototype implant design demonstrates extremely high resistance, design revision would be required.

Modifying the outflow tract of the AGV implant with ePTFE at physiologic flow rates increases the outflow resistance of the implant. This resistance contributed by the ePTFE was not constant. Instead, the added resistance was minimal at high flow rates. This effect may have been due to the enlargement of ePTFE pores at supra-physiologic flow rates. These findings may be valuable for the future design of GDDs. If GDD such as the AGV implant is modified with ePTFE or another porous, *in vivo* capsule altering material, it may be pragmatic to modify the valve to provide less resistance. Likewise, there may also be a therapeutic benefit to disabling the valve after several weeks to minimize valve-induced flow resistance after the capsule matures. Supporting this assertion is a simulated implantation model of the AGV where a polyimide microtube was used to stent open the valve. This stent lowered IOP by 7–8 mm Hg at a flow rate of 2.5 microliters per minute.<sup>33</sup>

Ultimately, our goal is to reduce the progressive fibrosis that occurs adjacent to the drainage device. Porous implant morphology is known to induce a less fibrotic foreign body reaction.<sup>17,26</sup> The modestly elevated initial resistance of the PRIME-Ahmed could be countered by reducing the opening pressure of the inner valve. More important is whether the PRIME-Ahmed favorably reduces the aggressive foreign body tissue reaction and elicits a thinner, more vascular capsule. Altering the capsule may decrease resistance to outflow and improve convective transport of fluid away from the device, compared to the resistance generated by the typically dense, minimally vascular capsules surrounding glaucoma implants.

An ideal valve would provide high resistance at low flow rates and, above a threshold, would open completely to provide a constant nearly zero resistance. Our study also confirms that the AGV performs as a non-ideal valve.<sup>34,35</sup> At pressures of 8–9 mm Hg, the AGV is approximately 76% “open.” That is, at low constant flow rates the AGV has high resistance, but is not completely closed. The incidence of post-operative hypotony when using AGV implants is reported by some to be 9–14%.<sup>10,36,37</sup> The effect of the valve is to tend to maintain pressure within a narrow range over a wide range of flows.

Our study reports that modifying the outflow tract of a GDD with ePTFE adds resistance to the system and that the Ahmed glaucoma valve implant behaves as a variable resistor. Future investigation will assess *in vivo* the combined effects of adding serial resistance via a porous membrane enclosure while simultaneously decreasing resistance by promoting a thinner, more vascular capsule by the same membrane.

## ACKNOWLEDGMENTS

The authors acknowledge that this study was supported in part by NIH R43 EY015587, the Ruth W. Morrow Glaucoma Research Fund, and a grant from New World Medical, Inc., Rancho Cucamonga, CA.

**Declaration of interest:** The authors have no intellectual property protection for the ePTFE-enclosed drainage devices, and they have no financial interest in New World Medical.

## REFERENCES

- [1] Lim KS, Allan BD, Lloyd AW, et al. Glaucoma drainage devices: Past, present, and future. *Br J Ophthalmol.* 1998;82:1083–1089.
- [2] Wilson MR, Mendis U, Smith SD, et al. Ahmed glaucoma valve implant vs trabeculectomy in the surgical treatment of glaucoma: A randomized clinical trial. *Am J Ophthalmol.* 2000;130:267–273.
- [3] Wilson MR, Mendis U, Paliwal A, et al. Long-term follow-up of primary glaucoma surgery with Ahmed glaucoma valve implant versus trabeculectomy. *Am J Ophthalmol.* 2003;136:464–470.
- [4] Gedde SJ, Schiffman JC, Feuer WJ, et al. Treatment outcomes in the tube versus trabeculectomy study after one year of follow-up. *Am J Ophthalmol.* 2007;143:9–22.
- [5] Gedde SJ, Schiffman JC, Feuer WJ, et al. Three-year follow-up of the tube versus trabeculectomy study. *Am J Ophthalmol.* 2009;148:670–684.
- [6] Topouzis F, Coleman AL, Choplin N, et al. Follow-up of the original cohort with the Ahmed glaucoma valve implant. *Am J Ophthalmol.* 1999;128:198–204.

- [7] Stein JD, McCoy AN, Asrani S, et al. Surgical management of hypotony owing to overfiltration in eyes receiving glaucoma drainage devices. *J Glaucoma*. 2009;18:638–641.
- [8] Nouri-Mahdavi K, Caprioli J. Evaluation of the hypertensive phase after insertion of the Ahmed glaucoma valve. *Am J Ophthalmol*. 2003;136:1001–1008.
- [9] Feldman RM, el-Harazi SM, Villanueva G. Valve membrane adhesion as a cause of Ahmed glaucoma valve failure. *J Glaucoma*. 1997;6:10–12.
- [10] Hong CH, Arosemena A, Zurakowski D, et al. Glaucoma drainage devices: A systematic literature review and current controversies. *Surv Ophthalmol*. 2005;50:48–60.
- [11] Classen L, Kivela T, Tarkkanen A. Histopathologic and immunohistochemical analysis of the filtration bleb after unsuccessful glaucoma seton implantation. *Am J Ophthalmol*. 1996;122:205–212.
- [12] Coleman AL, Mondino BJ, Wilson MR, et al. Clinical experience with the Ahmed glaucoma valve implant in eyes with prior or concurrent penetrating keratoplasties. *Am J Ophthalmol*. 1997;123:54–61.
- [13] Minckler D. Advances with aqueous shunts—1990 to 2001. *J Glaucoma*. 2001;10:S85–S87.
- [14] Ayyala RS, Harman LE, Michelini-Norris B, et al. Comparison of different biomaterials for glaucoma drainage devices. *Arch Ophthalmol*. 1999;117:233–236.
- [15] Ayyala RS, Michelini-Norris B, Flores A, et al. Comparison of different biomaterials for glaucoma drainage devices: Part 2. *Arch Ophthalmol*. 2000;118:1081–1084.
- [16] Salzman DL, Kleinert LB, Berman SS, et al. The effects of porosity on endothelialization of ePTFE implanted in subcutaneous and adipose tissue. *J Biomed Mater Res*. 1997;34:463–476.
- [17] Sharkawy AA, Klitzman B, Truskey GA, et al. Engineering the tissue which encapsulates subcutaneous implants. I. Diffusion properties. *J Biomed Mater Res*. 1997;37:401–412.
- [18] Sharkawy AA, Klitzman B, Truskey GA, et al. Engineering the tissue which encapsulates subcutaneous implants. II. Plasma-tissue exchange properties. *J Biomed Mater Res*. 1998;40:586–597.
- [19] Sharkawy AA, Klitzman B, Truskey GA, et al. Engineering the tissue which encapsulates subcutaneous implants. III. Effective tissue response times. *J Biomed Mater Res*. 1998;40:598–605.
- [20] Costa VP, Azuara-Blanco A, Netland PA, et al. Efficacy and safety of adjunctive mitomycin C during Ahmed glaucoma valve implantation: A prospective randomized clinical trial. *Ophthalmology*. 2004;111:1071–1076.
- [21] Kurnaz E, Kubaloglu A, Yilmaz Y, et al. The effect of adjunctive Mitomycin C in Ahmed glaucoma valve implantation. *Eur J Ophthalmol*. 2005;15:27–31.
- [22] Lee D, Shin DH, Birt CM, et al. The effect of adjunctive mitomycin C in Molteno implant surgery. *Ophthalmology*. 1997;104:2126–2135.
- [23] Tribble JR, Brown DB. Occlusive ligature and standardized fenestration of a Baerveldt tube with and without antimetabolites for early postoperative intraocular pressure control. *Ophthalmology*. 1998;105:2243–2250.
- [24] Al-Mobarak F, Khan AO. Two-year survival of Ahmed valve implantation in the first 2 years of life with and without intraoperative mitomycin-C. *Ophthalmology*. 2009;116:1862–1865.
- [25] Alvarado JA, Hollander DA, Juster RP, et al. Ahmed valve implantation with adjunctive mitomycin C and 5-fluorouracil: Long-term outcomes. *Am J Ophthalmol*. 2008;146(2):276–284.
- [26] Brauker JH, Carr-Brendel VE, Martinson LA, et al. Neovascularization of synthetic membranes directed by membrane microarchitecture. *J Biomed Mater Res*. 1995;29:1517–1524.
- [27] DeCroos FC, Ahmad S, Kondo Y, et al. Expanded polytetrafluoroethylene membrane alters tissue response to implanted Ahmed glaucoma valve. *Curr Eye Res*. 2009;34:562–567.
- [28] Bensen CV, Vann RD, Koger KE, et al. Quantification of gas denucleation and thrombogenicity of vascular grafts. *J Biomed Mater Res*. 1991;25:373–386.
- [29] Madras PN, Ward CA, Johnson WR. Enhanced thromboresistance of surfaces by denucleation. *Trans Am Soc Artif Intern Organs*. 1980;26:153–158.
- [30] Ritter EF, Vann RD, Wyble C, et al. Hydrostatic pressure reduces thrombogenicity of polytetrafluoroethylene vascular grafts. *Am J Physiol*. 1989;257:H1076–H1081.
- [31] Prata JA, Jr., Mermoud A, LaBree L, et al. In vitro and in vivo flow characteristics of glaucoma drainage implants. *Ophthalmology*. 1995;102:894–904.
- [32] Brubaker RF. Flow of aqueous humor in humans [The Friedenwald Lecture]. *Invest Ophthalmol Vis Sci*. 1991;32(13):3145–3166.
- [33] Pan T, Stay MS, Barocas VH, et al. Modeling and characterization of a valved glaucoma drainage device with implications for enhanced therapeutic efficacy. *IEEE Trans Biomed Eng*. 2005;52:948–951.
- [34] Francis BA, Cortes A, Chen J, et al. Characteristics of glaucoma drainage implants during dynamic and steady-state flow conditions. *Ophthalmology*. 1998;105:1708–1714.
- [35] Eisenberg DL, Koo EY, Hafner G, et al. In vitro flow properties of glaucoma implant devices. *Ophthalmic Surg Lasers*. 1999;30:662–667.
- [36] Coleman AL, Hill R, Wilson MR, et al. Initial clinical experience with the Ahmed glaucoma valve implant. *Am J Ophthalmol*. 1995;120:23–31.
- [37] Ayyala RS, Zurakowski D, Smith JA, et al. A clinical study of the Ahmed glaucoma valve implant in advanced glaucoma. *Ophthalmology*. 1998;105:1968–1976.