

## PROPORTIONAL CONTROL - TRUE PHYSIOLOGICAL CONTROL -

Marty Robinson, B.Sc., C.P. (c), Otto Bock Orthopedic Industry of Canada

### Introduction

'Nothing like the human hand' [1] is the title of Boivin's 1968 article reviewing current research and development in prosthetic hands at that time. This title holds true even today although technological advances have allowed amputees access to componentry offering greater function, cosmesis and efficiency of control. Childress also reminds us that hand replacement by means of prosthetic intervention is one of the most challenging problems of rehabilitation "if one agrees the hand is 'the finest tool of all' or the 'instrument of instruments' as Aristotle called it" [4].

Myoelectric control of an electric terminal device has evolved very slowly since its conception by Reiter [14] in post World War I Germany. Many early developments included crude control parameters still being refined today [20]. Very early in this century recognition was given to the importance of feedback in the form of tactile sensation as a design consideration for hand prostheses [15]. The Vaduz prosthesis of the 1940's allowed the wearer to receive force feedback as they were required to move against an air filled bag secured within the socket to operate the terminal device [11]. The refinement and incorporation of both sensory and proprioceptive feedback loops within powered prostheses remains the focus of recent research [3, 6, 9, 13, 17, 18, 19, 22].

Shortly after Kobrinski's [8] introduction of a functional myoelectric prosthesis in 1960 with basic digital (on/off) control, Bottomley [2] introduced the concept of proportional control to this field. With Bottomley's system the myoelectric signal had a fairly linear relationship to velocity when the hand was moving and a similar relationship to grip force when the hand was closed. This concept was not revisited until quite recently.

Presently, the digital control system remains a common prescription option for the below elbow amputee. Although feedback is limited to visual and incidental information with the digital control system [4], many experienced myo-users develop a sense of feedback incidentally through vibration recognition of the motor activity in the terminal device [23].

Sears and Shaperman made some significant conclusions upon completion of their 1991 survey that evaluates proportional myoelectric hand control. They define a proportional control system as one in which "the amplitude of the hand motor voltage, and thus its speed and force, varies in direct proportion to the amplitude of the EMG signal generated by the wearer" [21]. The digital system is more simply an on/off threshold system that allows the user to reach a maximum grip strength limit when a contraction is maintained over time [5].

The proportional control system used in the paper by Sears and Shaperman [21] was modified for below-elbow amputees from the hand-controller for the above-elbow Utah arm from Motion Control [7]. The below elbow proportional control system presently available from Motion Control is the Pro Control System [12]. It is interesting to note that all of the thirteen previous digital hand wearers using the proportional control system in Sears and Shaperman's study [21] rated it higher than digital control for performance. These subjects indicated benefit from ease of operation and quickness of hand opening and closing response. The thirteen previous digital hand wearers clearly defined control of grip force as the most valued feature of the proportional hand. The one notable disadvantage realized by this same group was the added weight of the proportional control system [21]. The Pro Control System from Motion control [12], as well as other proportional controls such as the VARI-GRIP from Liberty Mutual Research Centre [24] add more weight (not in all cases) and usually require further fabrication steps to incorporate them into the finished prosthesis. One of the newest control systems on the market is the Dynamic Mode Control (DMC) developed by Otto Bock Orthopedic Industry.

### DYNAMIC MODE CONTROL DMC

The term DMC refers to the alternative dynamic control of two operational modes. The electronics were developed to convert a conscious muscle contraction into an interference-free control signal for hand operation. Depending on the position of a special grip force switch, either the grip movement or the grip force is proportionally controlled. The patient is therefore able to grasp an object with a certain closing velocity and to hold that object with a grip force determined by that individual.

#### Outcome Goals for the DMC System

The following goals were realized with this design;

- The patient should be able to work with the system without necessitating a lengthy learning/training period.
- The system should not differentiate itself from the standard modular MYOBOCK components and should not require hybridization.
- Restrictive parameters such as observing a minimum time or exceeding a threshold are removed.
- The patient should be able to manipulate small objects with precision while regulating grip force.
- Time consuming calibration measures are omitted with the only adjustment being the electrode sensitivity.

#### Design Background

In order to operate the system, two separate electrode signals from the two antagonists are required. The appropriate muscle signals are gathered and sent to the control electronics as speed and direction information.

Rather than evaluating the electrode signal digitally with thresholds, the plan was to create a signal proportional to the muscle signal for the speed of the hand. In realizing this goal, a natural limit of the muscle signal was identified [5, 10]. A signal generated and picked up on the skin's surface is composed of a mixture of motor units with different values. A clearly defined control unit is not achieved but rather a mixture of signals that are not linear. To establish the correlation between muscle contraction and the resulting myo signal, a simple test was carried out.

### Test & Results

Electrode myo signals were recorded during muscle contraction in a relaxed and contracted state of the wrist extensors of an intact forearm.

Two trials were completed and the corresponding myo signals were recorded. A statistical evaluation of the outcome revealed a non-linear relationship. In other words, although maximum muscle contraction delivered 100% myo signal, 50% of maximum muscle contraction did not deliver 50% of the maximum myo signal.

The results revealed that movements at approximately 10% of maximum muscle contraction in both a relaxed and contracted state displayed a very high relative myo signal. This test clearly indicates that precise movement of the electric hand requiring low level myo signals would be compromised by a direct (1:1 ratio) proportional control system. Interference within the range of minimal myo signals has a much greater impact. It is for this reason that the myo signal cannot be utilized as a 1:1 control signal for the motor without restrictions [ 10].

### DMC Design and Function

The DMC's main functions can be explained simply with reference to Figure 1. The INPUT variables are the opening and closing electrode signals and the condition of the power switch. Both electrode signals are locked and filtered.

The condition of the grip force switch separates the system into two control loops. If the switching point, a corresponding grip force, is not reached, the system operates by proportional speed control. When going over the switching point, the system changes over to proportional grip force control.

#### Control Loop 1 (Proportional Speed)

The grip force switch is not active and the wanted electrode voltage (open or closed) is converted with the help of a table and fed to the actual controller. The signal is read a conversion table and altered in a way that the connection between the neuro-muscular system and the resulting myo-hand movement feels natural to the DMC user.

It has therefore become possible to carry out an adaptation to certain r.p.m. characteristics of the electrode signal. Small input signal interference is simply hidden by the conversion with the matrix parameters and individual characteristics are created simultaneously. The resultant set value and the measured motor current (r.p.m.) at that specific moment (actual value) are both fed into the controller electronics that regulate the motor. The motor will therefore rotate with a speed proportional to the actual electrode voltage.

### Control Loop 2 (Proportional Grip Force Control)

A predetermined magnitude of force exerted through the thumb and finger group will activate the grip force switch changing the system over to proportional grip force control.

The augmentation of grip force is analogous to that of speed. The set value is derived from the CLOSING site electrode signal that has been evaluated by a table. Again, this table converts the myo-signal in such a way that the link between the neuro-muscular system and the resulting grip force is felt to be natural or PHYSIOLOGICAL to the DMC user. The actual value (determined from the present motor current) and set value are differentiated by the controller electronics to regulate the motor appropriately.

The hand therefore operates with a grip force proportional to the CLOSED electrode signal.

### Conclusions

Although proportional control is not a revolutionary concept [2, 10, 16], it is certainly a desirable one with respect to the natural link it provides between the user and electric hand function [21, 5]. Advances in micro-chip technology as seen in the Dynamic Mode Control (DMC) system provide further refinement of the proportional relationship of myo signal to grip force and speed without adding weight, fabrication time, or complex calibrations.

The creation of matrices and conversion tables serve to remove interference and restore a more linear relationship between muscle contraction and myo signal, especially at lower signal levels where interference has a greater impact.

The integrated grip force switch "decides" whether to proportionally control speed or grip force. Ultimately, the overall gripping process with the DMC hand is physiologic where grasping of small or fragile objects is very effective.

As our knowledge and experience with feedback mechanisms and microchip technology continues to grow, inevitably the caliber of future control systems will rise to new heights in functionality and efficiency.

### DMC's Main Functions

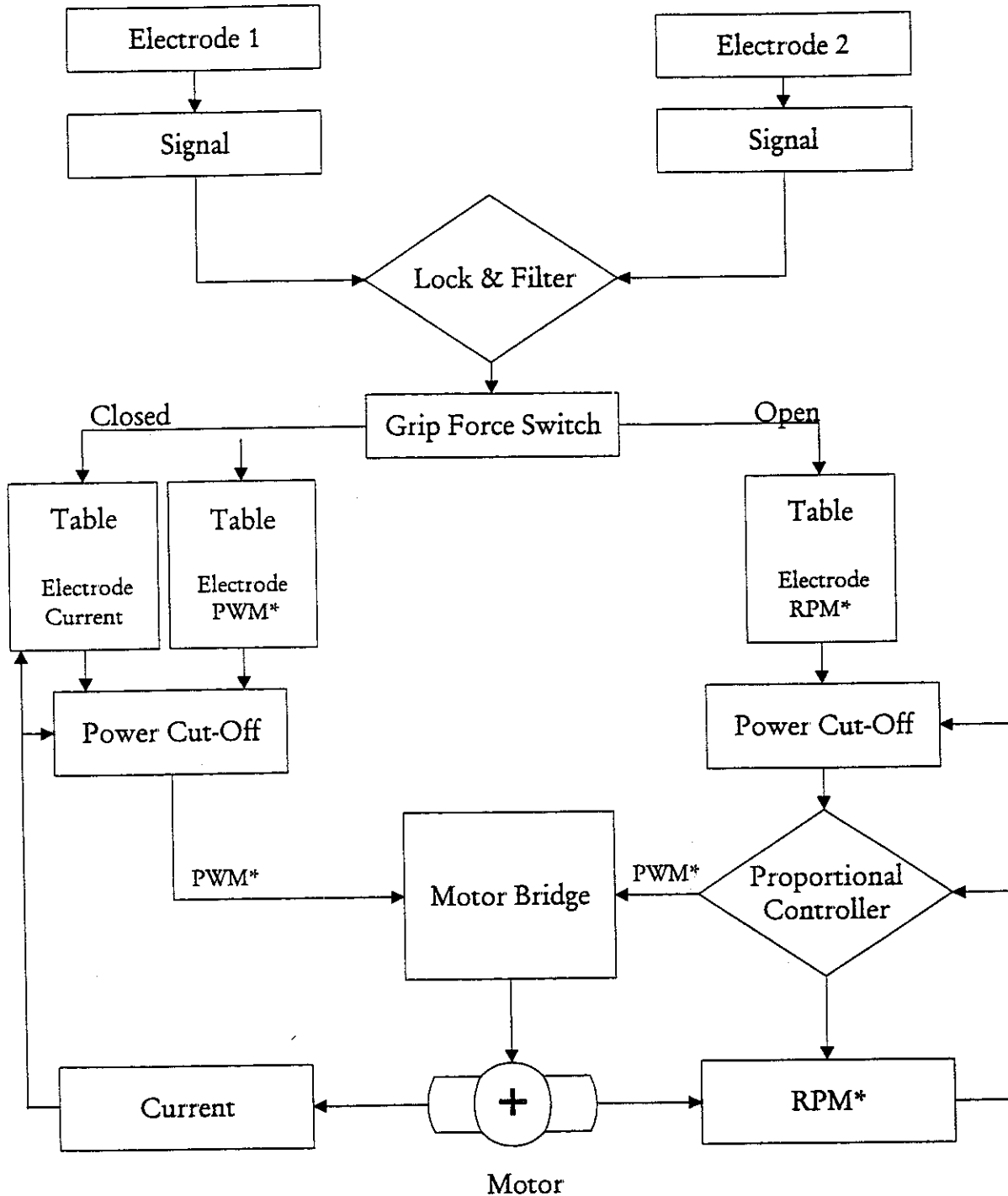

Figure 1

\*PWM - Pulse Width Modulation

\*RPM - Revolutions Per Minute

## Acknowledgement

Robert Kaitan, Otto Bock Austria for his insight into the DMC's design and function.

## References

1. Boivin, G., "Nothing like the human hand", ICIB, 7, 17-19, 1968.
2. Bottomley, A., "Myoelectric Control of Powered Prostheses", J. Bone Jt. Surg., 47B (3), 411-415, 1965.
3. Chappell, P.H., "Prehensile control of a hand prosthesis by a microcontroller", Biomed. Eng., 13, 363-369, 1991.
4. Childress, D.S., "Closed loop control in prosthetic systems: historical perspective", Ann. Biomed. Eng., 8, 293-301, 1980.
5. Evans, H.B. et al., "Signal processing for proportional myoelectric control", IEEE Trans. Biomed. Eng., 31, 207-211, 1984.
6. Herberts, P. et al., "Ideas on sensory feedback in hand prostheses", Prosthet. Orthot. Int., 3, 157-162, 1979.
7. Jacobsen, S.C. et al., "Development of the Utah Artificial Arm", IEEE Trans. Biomed. Eng., 29(4), 249-269, 1982.
8. Kobrinski, A.Y., "Bioelectric control of prosthetic devices", Herald of the Academy of Science- USSR (Vestn. Akad. Nauk SSSR), 30, 58-61, 1960.
9. Kyberd, P.J. et al., "Sensory control of a multifunction hand prosthesis", Biosensors, 3, 347-357, 1987/88.
10. Lozac'h, Y., et al., "A new versatile myoelectric proportional control unit", Bull. Prosthet. Res., 10, 16-23, 1971.
11. Lucaccini, L.F. et al., "The French Electric Hand: Some observations and conclusions", Bull. Prosthet. Res., 10, 6:30, 1966.
12. "More Information about the Utah Procontrol System", Product Bulletin, Motion Control, Division of IOMED, Inc., Salt Lake City, Utah, 1994.
13. Partridge, C., "Getting to grips with sensitive artificial limbs", Electron. Times, 162, 18-19, 1982.

- 14 Reiter, R., "*Eine neue elektrokunsthand*", Grenzgeb. Med. 4, 133-135, 1948.
- 15 Rosset, F., German Patent 3001108, "*Artificial Limbs*", Dec. 17, 1916.
- 16 Salisbury, L.L. et al., "*A mechanical hand with automatic proportional control of prehension: technical note*", Med. Biol. Eng., 5, 505-511, 1967.
- 17 Schmidl, H., "*The importance of information feedback in prostheses for the upper limb*", Prosthet. Orthot. Int., 1, 21-24, 1977.
- 18 Scott, R.N. et al., "*Sensory feedback system compatible with myoelectric control*", Med. Biol. Eng. Comput., 18, 65-69, 1980.
- 19 Scott, R.N., "*Feedback in Myoelectric Prosthesis*", Clin. Orthop., 256, 58-63, 1990.
- 20 Scott, R.N., "*Myoelectric control systems research at the Bioengineering Institute, University of New Brunswick*", Med. Prog. Technol., 16, 5-10, 1990.
- 21 Sears, H. et al., "*Proportional myoelectric hand control: an evaluation*", Am. J. Phys. Med. Rehabil., 70, 20-28, 1991.
- 22 Shannon, G.F. et al., "*Fitting below-elbow prostheses which convey a sense of touch*", Med. J. Aust., 24, 242-244, 1979.
- 23 Sorbye, R., "*Myoelectrically controlled hand prosthesis in children*", Int. J. Rehabil. Res., 1, 15-25, 1977.
- 24 "*VariGrip Control for Bock Hands*" and "*In-Forearm VariGrip Control*", Product Bulletin, Liberty Mutual Research Centre, Hopkinton, MA, 1993.